

# BIG SHOT

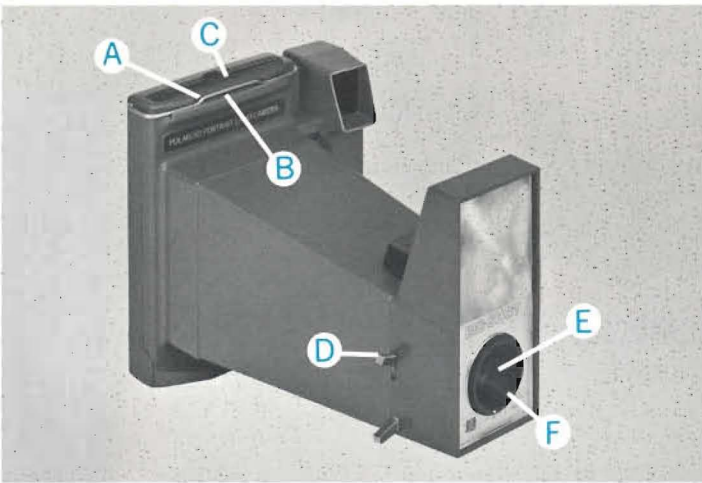

POLAROID PORTRAIT LAND CAMERA

## KNOW YOUR CAMERA



- A. Back lock
- B. White tab slot
- C. Yellow tab slot
- D. Shutter release
- E. Lens, single meniscus, 220 mm, f/29
- F. LIGHTEN/DARKEN control

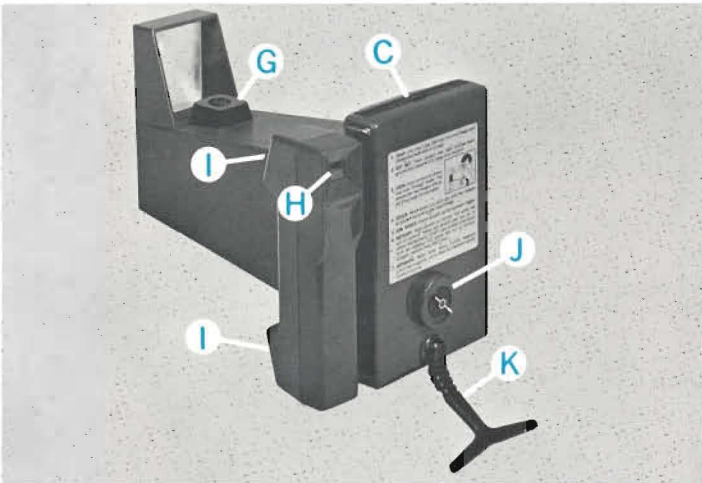

- G. Flashcube socket
- H. Rangefinder/viewfinder rear window
- I. Rangefinder/viewfinder front windows
- J. Development timer
- K. Flexible T handle

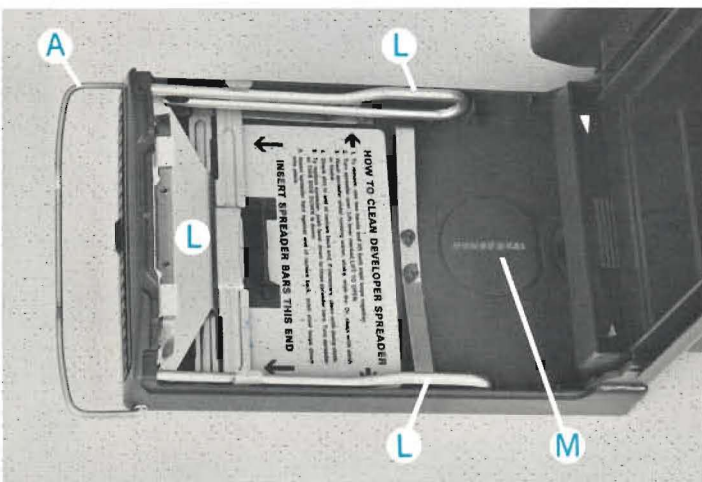

- L. Developer spreader
- M. Camera number

**IMPORTANT:** The developer spreader (L) must be kept clean or you won't get good pictures. Check it and clean it as shown on page 22.

**Development timer:** To operate it, turn the arrow clockwise all the way and let go; the timer will run for approximately one minute, the recommended development time for color pictures in ordinary room temperatures (about 75°F). At lower temperatures you must develop pictures for a longer time; see the film instructions for details.

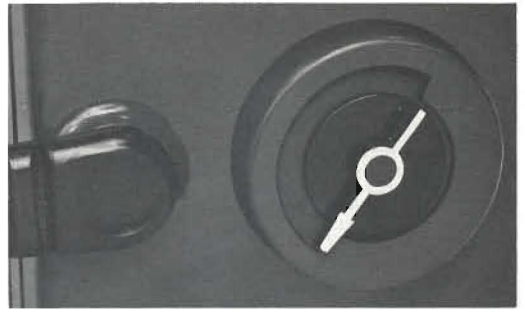

**Lighten/Darken control:** By turning the ring (F) you can adjust the amount of light reaching the film to make a picture lighter or darker, as desired, or to take care of differences in flashcubes or film packs. When and how to use the L/D control is explained on page 8. It is shown here set to the Normal position.

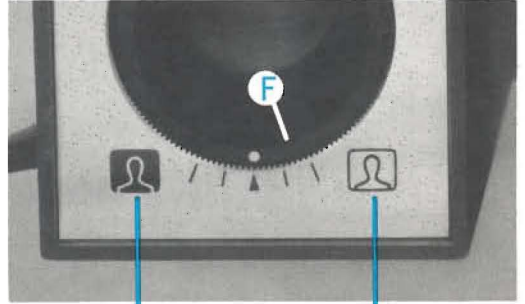

DARKEN

LIGHTEN

## YOU CAN MAKE THESE KINDS OF PICTURES WITH THIS CAMERA

**COLOR PICTURES** . . . . . Load the Big Shot only with Polaroid Polacolor Land film packs, Type 108. **Do not use Type 107 black and white film with this camera.**

**FLASH PICTURES.** . . . . . It is designed to use only the new batteryless Magicubes, or equivalent. Other kinds of cubes won't fit the socket. Pictures made without flash, even in bright daylight, will generally be too dark.

**PICTURES AT ONE DISTANCE.** . . . . The Big Shot's fixed focus lens is set to make sharp pictures when the subject is about 39 inches from the lens. A simple-to-use but accurate one-distance rangefinder puts you at the correct distance. Objects much closer or further than 39 inches will be out of focus.

**VERTICAL OR HORIZONTAL.** . . . . . You can hold the camera either way, as shown on page 4; the rangefinder works equally well in both positions.

**IMPORTANT.** . . . . . **Do not make flash pictures in explosive atmospheres.**

## HOW TO HOLD THE CAMERA



Grip the viewfinder housing firmly with your left hand. **Be careful not to cover the lower window of the rangefinder (A).** If you do, the rangefinder won't work. When developing pictures, hold the camera as shown on page 7.

You can operate the shutter release with either your forefinger or your thumb, as shown. Squeeze slowly and smoothly until the bulb flashes. Be careful not to shake the camera.

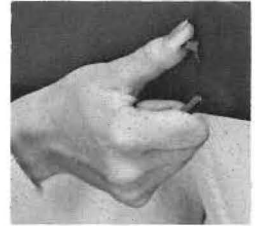
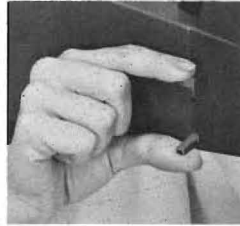
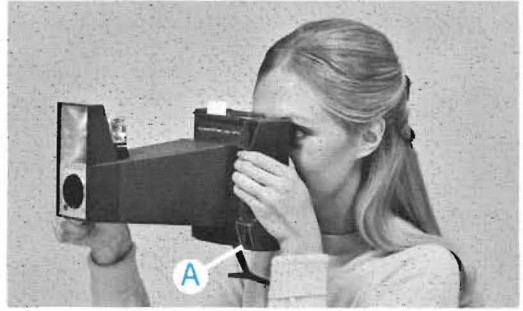

## HOW TO USE THE RANGEFINDER

Stand about 4 ft. away. Look through the bright spot at the most important part of your subject (eyes, for example). You should see two images (four eyes). This shows you are at the wrong distance. Move closer, or if too close back up, until the two images in the bright spot become a single, clear image of the most important part. You are now at the right distance. Disregard other parts of your subject which you may see in the bright spot.

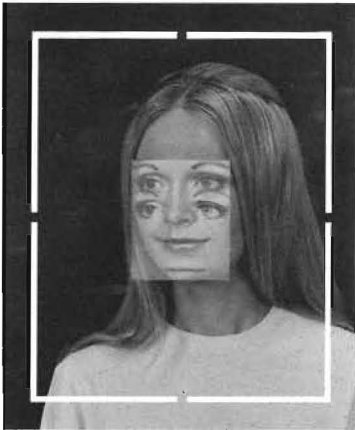

For a vertical picture

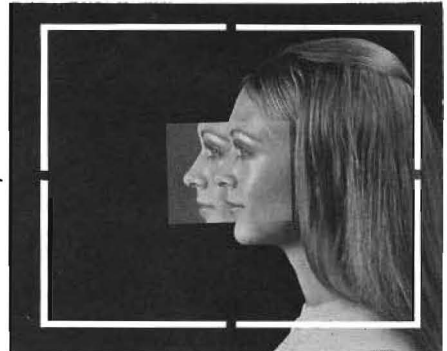

For a horizontal picture

OUT OF FOCUS  
(two images)

Move closer  
or back up



IN FOCUS  
(single image)



## HOW TO LOAD THE CAMERA WITH FILM

**The film:** Use only Polaroid Polacolor Land film packs, Type 108. Each pack makes eight pictures.

**1. Open the package:** Slide the foil bag out of the box. Handle it carefully and only by the edges. Tear the bag along the dotted line and remove the pack.

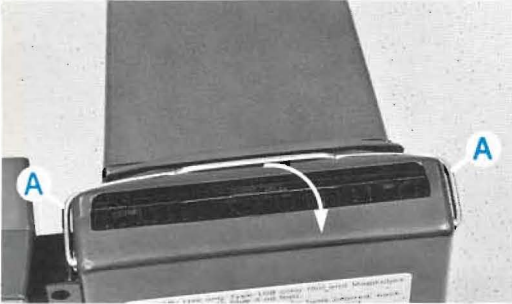

**2. Unlock and open the back:** Push up both ends of the back lock (A) and open the back all the way.

Hold it only by the edges. Discard the moisture absorbing card which is inside the foil bag with the pack (some packs may not have a card). Save the box and the foil bag for carrying prints and waste.

**Please read the instruction sheet carefully so you'll know how long to develop your pictures.**

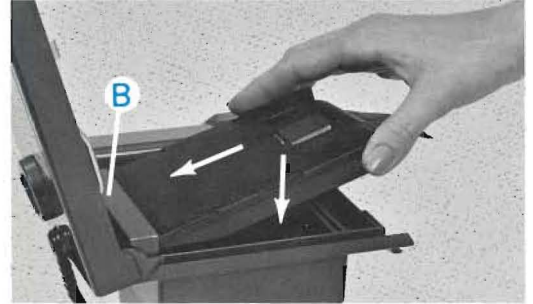

**3. Insert the pack:** Hold the film pack by the edges as shown. Push the closed end of the pack under the light shield (B) against a spring and then push the pack down into the camera.

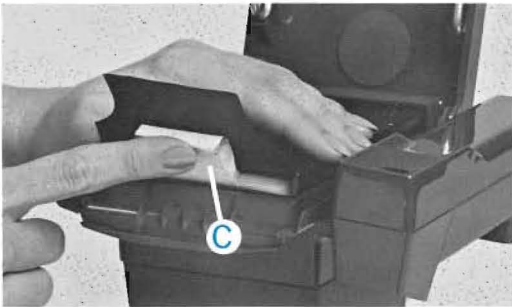

**4. Check the white tabs (C):** Be sure that they are not caught between the pack and the camera.

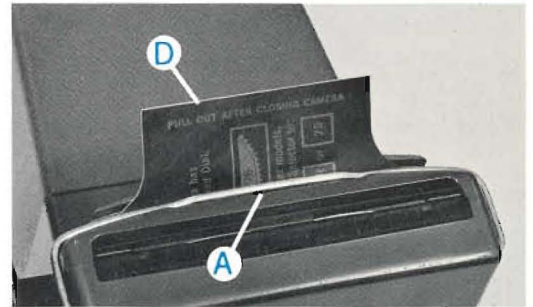

**5. Close and lock the back:** Hold the back closed and push down on the center of the lock (A). The black tab on the safety cover (D) should stick out behind the lock.



**6. Grip the black tab:** Hold the camera by the handle and get a grip on the black tab (D) as shown. The black tab is the end of the safety cover. **Pull the safety cover all the way out of the camera.** Pull it straight and be careful not to rip it.

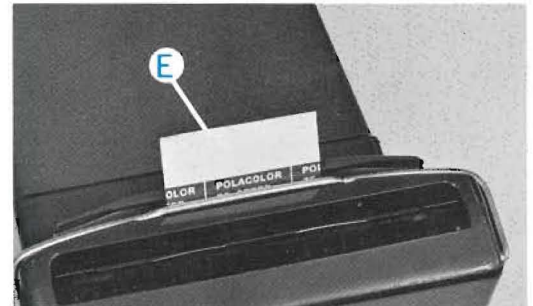

**7. Look for the white tab:** When the safety cover is removed, a white tab (E) should stick out of the small slot next to the lock.

**If you can see a white tab, you are now ready to take picture No. 1.**

**If there is no white tab:** Turn to page 23.



## BIG SHOT

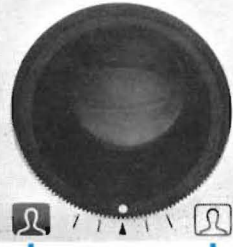

DARKEN

LIGHTEN

## LET'S MAKE A PICTURE

- 1. Insert a flashcube:** Use **only** batteryless Magi-cubes, or equivalent. Press the cube base into the socket firmly.
- 2. Check the L/D control:** Ordinarily, it should be left at the Normal position as shown. On the back of some color film packs you may find printed instructions advising you to set the L/D control one mark toward LIGHTEN for all pictures made with that pack. Please follow that advice; it's important.

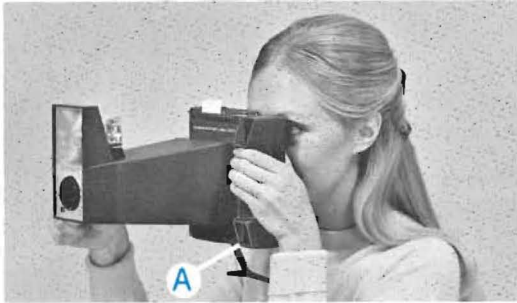

- 3. Get set:** Place your subject close to a background, which should be brightly colored, if possible. Stand about 4 ft. away.

- 4. Look:** Hold the camera as shown. **Be careful not to cover the lower window (A) of the rangefinder.** Look through the bright spot at the most important part of your subject (eyes, for example). You should see two images (four eyes). This shows that you are standing at the wrong distance from your subject.



OUT OF FOCUS



IN FOCUS

- 5. Focus:** Move closer (and if you get too close, back up) until the two images in the bright spot become a single, clear image of the most important part. You are now at the right distance. Disregard other parts of your subject which you may see in the bright spot.

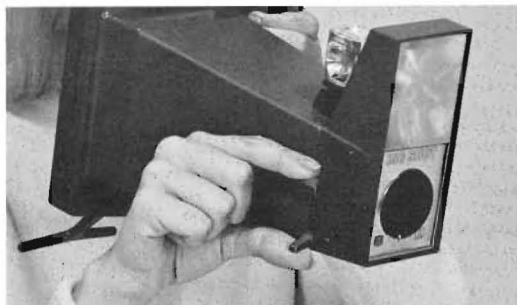

- 6. Aim and shoot:** Make sure your subject is nicely placed within the bright frame line. Gently squeeze the shutter release with your forefinger or thumb until the flash fires. Then let go of the shutter release, which will pop up again. The flashcube automatically turns 90° after each flash.

**After four flashes the shutter release will not pop up; this is the signal to insert a new cube.**

# HOW TO DEVELOP YOUR PICTURE

## FIRST, PULL THE WHITE TAB OUT OF THE CAMERA



**1. Let the camera hang freely:** Hold it by the flexible T handle. **Don't hold onto the camera body!**



**2. Pull the white tab (A) all the way out of the camera:** This causes a yellow tab (B) to pop out of a narrow opening in the end of the camera.

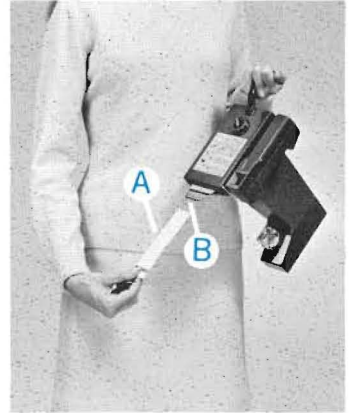

### IF A YELLOW TAB DOES NOT COME OUT, DON'T PULL ANOTHER WHITE TAB!

The tab usually gets jammed because of dirt in the developer spreader. First, remove the jammed yellow tab, as shown on page 23. Then clean the developer spreader (see page 22).

### NEVER PULL A WHITE TAB IF YOU CAN SEE A YELLOW TAB, OR YOU WILL CAUSE THE FILM TO JAM!

If you accidentally pull a white tab while a yellow tab is showing, don't pull another. Instead, follow the steps shown on page 23.

## THEN, THE YELLOW TAB



**3. Grip the center of the yellow tab.**



**4. Pull the yellow tab all the way out of the camera:** As you pull the tab out with your right hand, pull the camera to your left with the T handle. Pull smoothly, at medium speed, without slowing down or stopping.



**THE PICTURE IS NOW DEVELOPING OUTSIDE THE CAMERA, SO START THE DEVELOPMENT TIMER RIGHT AFTER PULLING THE TAB OUT. NEXT PAGE, PLEASE.**

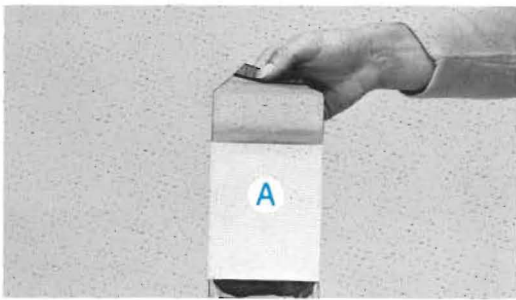

**5. Develop the picture for the full time given in the film instruction sheet:** Let the film hang from the yellow tab without moving, or lay it down flat.

**Don't touch or bend the part where the picture is developing** (A).

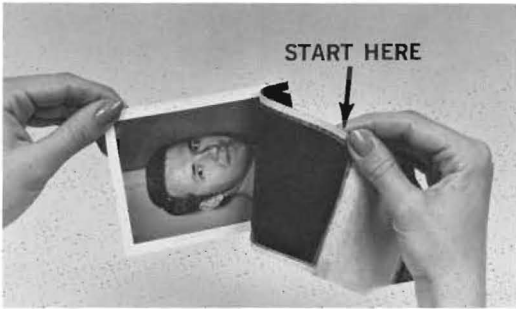

**6. Separate the print:** After the full development time, **quickly lift the print** away from the rest of the paper, starting from the end near the yellow tab, as shown. **Don't start at the other end;** you will get developer chemicals on your fingers.

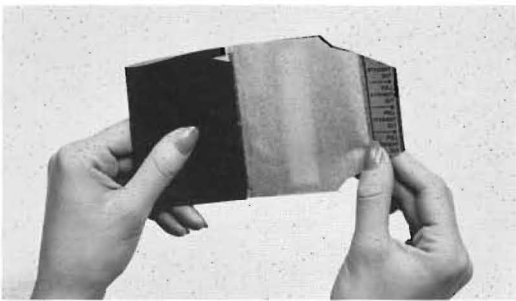

**7. Fold up the negative:** To avoid touching chemicals left after the print is removed, fold up the negative with the moist side in. Please put it in a wastebasket.

**Caution:** Please be sure to read the CAUTION notice on page 24.

### HOW TO MAKE YOUR NEXT PICTURE LIGHTER OR DARKER

If the camera's LIGHTEN/DARKEN control was at the Normal position, as shown, and if you used the rangefinder correctly, your picture should be well exposed and in sharp focus.

However, variations in flashcubes may cause some pictures to be lighter or darker than others, or you may want a picture to be lighter or darker for reasons of personal taste.

To make the next picture of the same subject lighter or darker, adjust the LIGHTEN/DARKEN control. For a small change, turn it one mark toward the LIGHTEN or DARKEN symbol; for a greater change, move it two marks. Don't forget to return the L/D control to the Normal position when a special setting is no longer necessary.

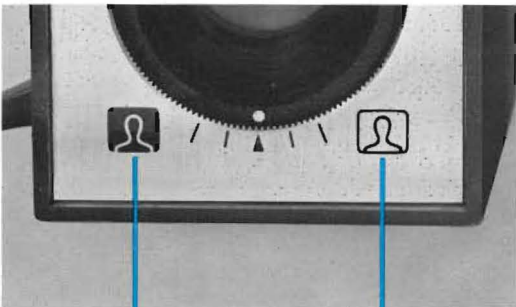

DARKEN

LIGHTEN

### CARE OF COLOR PRINTS

A newly separated color print will look nearly dry, but it is actually slightly moist and the surface can be damaged by handling. Don't touch the surface for a few minutes; it will dry hard and glossy.

**Be sure the print is fully dry** before allowing it to touch another print, or the two may stick together.

When the print is dry, protect it against curling, cracking, etc. by putting it on one of the cardboard mounts supplied with the film.

The dyes used to form colors in the prints are long lasting. However, like all dyes, they will fade if exposed to bright light for long periods of time. The best way to protect your prints is to keep them in Polaroid Picture Albums.



## TRY THESE 20 IDEAS FOR BETTER PICTURES

Here are 11 pages of Big Shot pictures — 20 examples of the many kinds of beautiful and exciting color photos it's easy to make with this camera.

Each presents at least one picture idea. If you did nothing more than imitate them (we suggest that you do so) you'd have a wonderful picture collection. We hope that your results will make you want to try many other ideas of your own.

One word of caution: This camera is very simple to use but, even so, you must know what to do with it to make pictures like these. So, **please read the entire instruction book carefully.**



### FIRST RULE — HAVE A GOOD BACK-

**GROUND:** Always try to place your subject close to a good background, preferably one that is brightly colored. A wall, a door, a curtain, even a large picture, can make a good background. Try to pick one that contrasts with the color of your subject's hair and clothing — that helps to separate the subject from the background. The top picture is a good example.

In the bottom picture the background was so far away the light from the flash did not reach it and the outline of the head is not clear. However, for a subject with white hair, such a background would not be bad; try it some time.





**FINGERS WILL DO:** Here you see only part of the man's hands, but there's no doubt about what the "action" is. Whether they're old and gnarled or young and graceful, hands can add much to portraits.



**BE A DIRECTOR:** An easy way to get a more natural looking picture is to have your subjects use their hands for some simple activity, such as picking up the phone, or pouring something colorful, or holding an ice cream cone, apple, etc.

**LOOK FOR INTERESTING ANGLES:** Heads and hands don't have to be straight and upright. The tilted head, the sweep of the hair, the angle of the hand, and the graceful curve of the fingers, all help to make this an engaging picture.



**CATCH A FAMILIAR POSE:** Does he frequently hold a pipe, or tug at an ear, or rest his chin on his fist, or fold his hands behind his head? Many people have characteristic actions that would look good in a picture. Set the scene, wait for the action (or ask for it) and shoot the picture.



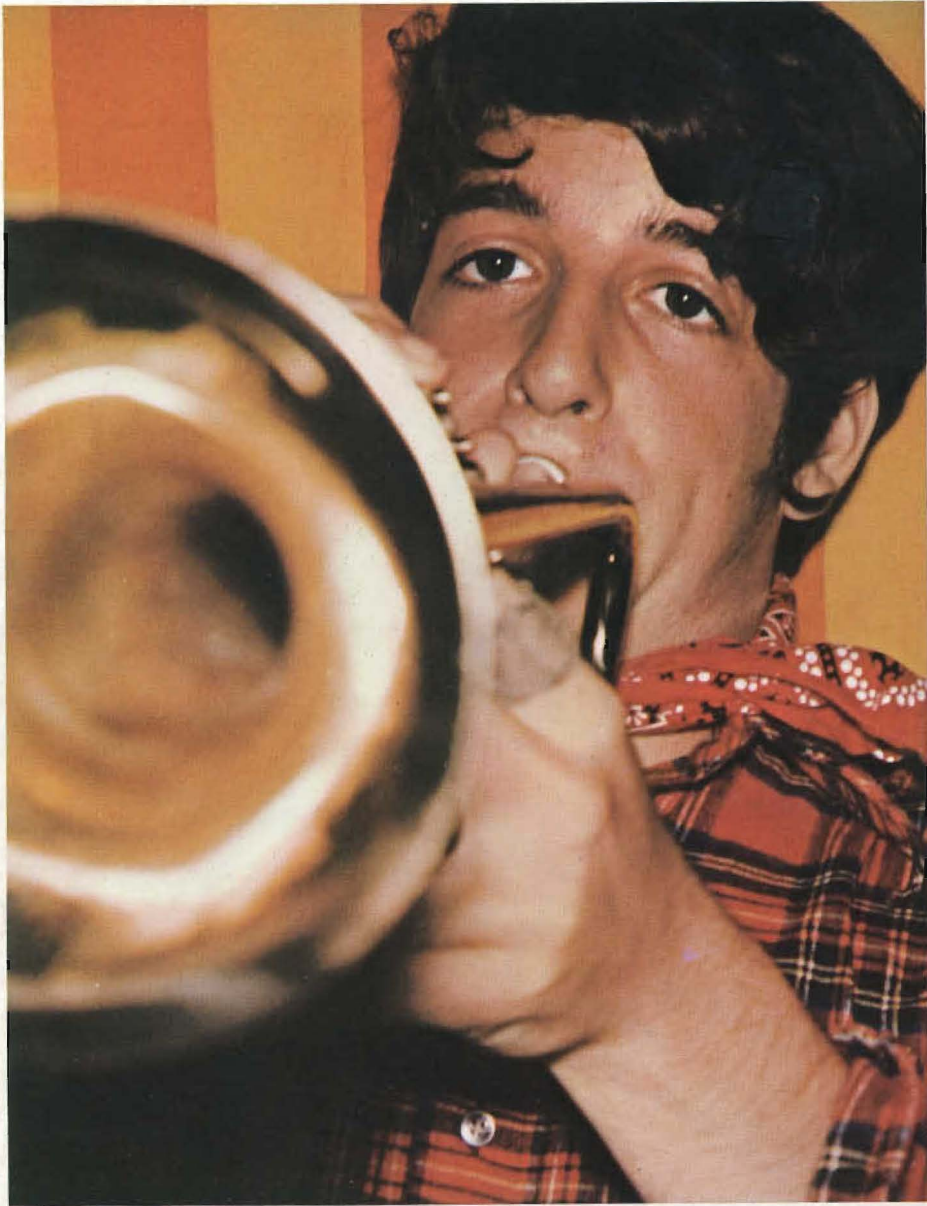

**TRY SOMETHING OUT OF FOCUS:** The range-finder is designed to provide sharp pictures when the subject is about 39 in. from the lens. Actually, everything from about 36 in. to about 42 in. from the camera will be sharp. Ordinarily, you should try to have all the important parts of the subject about the same distance from the camera so the whole picture will be in sharp focus (see the picture at right). How-

ever, putting part of the subject out of focus on purpose can improve some pictures. This is called selective focus. Much of the impact of the picture above comes from the horn, which is blurred because it is too near. Yet, just because it is unsharp, your eyes are drawn to the trumpeter. This also could have been shot with the horn in sharp focus and the boy out of focus.

## ENLARGEMENTS ARE GREAT

Your Big Shot pictures can make outstanding enlargements. Three sizes are available from Polaroid Copy Service — 5 x 7 inches, 8 x 10, and 11 x 14. Careful attention is given to faithfully reproducing your picture and minor retouching is provided where necessary. All sizes come in attractive salon mounts.

To make really good enlargements you must start with a sharply focused, well exposed picture with plenty of color in it. Try to avoid scratching or fingerprinting pictures that are to be enlarged. Remember, the better your original picture, the better the enlargement.



## TRY SOME HORIZONTAL PICTURES, TOO



**MORE ROOM FOR HANDS AND ARMS:** For horizontal pictures hold the camera as shown on page 4. The rangefinder image then moves sideways. The nose is a good point to focus on, or one eye. It's particularly easy to focus for profile shots.

**BEST FOR BABY PICTURES:** Infants photographed alone are generally lying down. In the usual vertical picture the face is furthest from the camera. That's not good. Instead, place the baby at right angles to the camera, as shown here, and shoot a horizontal. A bright colored blanket makes an ideal background.





**FRAME SUBJECTS CAREFULLY:** Fitting two adult heads into a vertical picture requires some care. Don't be surprised or discouraged if you have to leave out an ear, or part of a hairdo. You can still make a fine picture even if some bits and pieces are missing. For two subjects, it's usually easier to shoot a horizontal picture.

**YOU CAN CONTROL THE SHADOWS:** To avoid unpleasant edge shadows, keep your subjects close to the background. If you aim through the viewfinder with your left eye, any shadow will be cast slightly toward the right side of the subject. If you aim with the right eye, the shadow will go slightly toward the left side of the subject. You will get the worst shadow (to the left of the subject) in a horizontal picture when you have aimed with the right eye, as shown below.



## INCLUDE MORE THAN ONE (cont.)



**PUT BIG AND LITTLE TOGETHER:** Contrasts in color add interest to pictures; so do contrasts in size. Placing the baby's tiny hand next to the mother's emphasizes how small the infant really is. And the little boy's head makes it clear that the dog's head is as big as a pumpkin.







**FOR MORE ROOM, HIGH AND LOW:** Two heads need not be side by side in a vertical picture. With one high in the picture and one low there's almost as much room as in a horizontal shot.

**ADD AN OBJECT FOR A SUBJECT:** Want a second subject to fill the print? Include a picture on the wall, a piece of sculpture, a giant doll or animal toy, or a work of art such as that shown here.



## PEOPLE AREN'T THE ONLY SUBJECTS

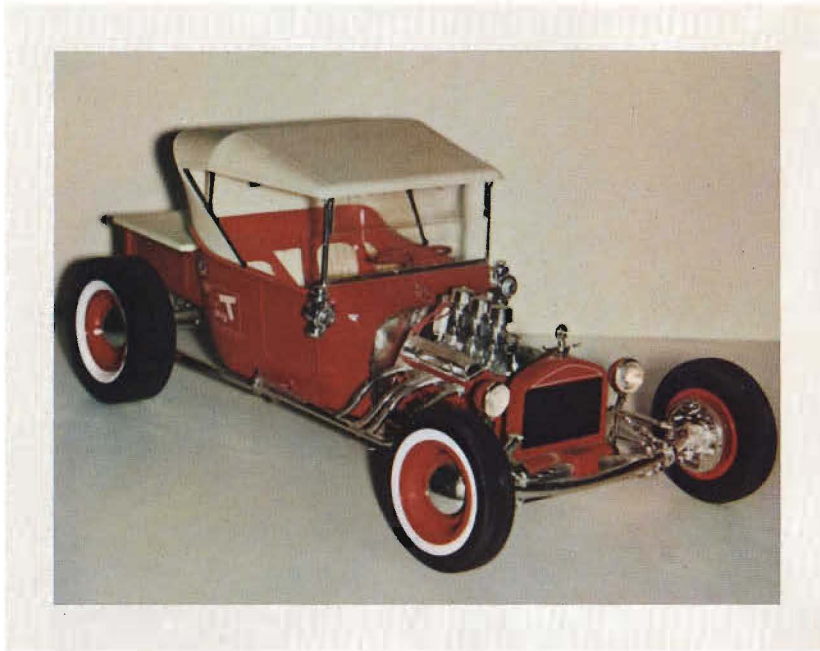

**SHOW THAT MODEL:** If it will fit in a 12 x 16 in. space, you can get it all into the picture. If it's too big, like the ship below, turning it at an angle may make it fit. Or, you may have to settle for just part of the model. If you have small models, set up a fleet of ships, a squadron of planes, or a company of soldiers ready to parade.





**FAUNA, FLORA, AND OTHERS:** Cats are not quite big enough to fill the picture area, but bright cushions can supply bulk, color, and background. Some dogs may take off when you aim the Big Shot their way. Flowers should have bright colors and be in big masses so they'll show up well. And don't forget that stuffed animal toys, artificial flowers, and similar items can be wonderful subjects for colorful pictures. For example, this crustacean happens to be made of wood.



**RECORD ART AND BRIC-A-BRAC:** The Big Shot is great for recording valued and favorite items. Results can be outstanding with matte surfaces, such as needlework, pictures not under glass, and unpolished wood carvings. Shiny surfaces may cause reflections of the flash to appear in the picture; you can cut them somewhat by shooting from an angle.

## WHAT ABOUT TAKING PICTURES IN DAYLIGHT?

**Daylight pictures without flash:** This camera is designed for use only with flash. Pictures made in daylight without flash usually will be too dark. If the subject is in bright sunlight, as on a beach, and if the L/D control is turned all the way to LIGHTEN it is possible to produce interesting and attractive pictures. However, we **do not** recommend that you try to take pictures this way unless you are prepared to do some experimenting and perhaps waste some film. For consistently good results, all Big Shot pictures should be made with flash.

**Flash combined with daylight:** There is no reason why all Big Shot flash pictures have to be made

indoors. You can shoot them on a covered porch, or elsewhere in the shade, or even outside on a bright day. However, you will have to experiment with the LIGHTEN/DARKEN control to get a well exposed picture; the brighter the daylight, the further you will have to turn the control toward DARKEN. Interesting, colorful backgrounds are just as important for flash/daylight pictures as for those made with flash alone.

**IMPORTANT:** Development of Polacolor pictures is strongly affected by the temperature at the time of development. If it is less than 75°F you will have to develop for a longer than normal time. See the film instructions for details.

## GENERAL CARE OF CAMERA AND FILM

**Protect film and camera from heat and humidity:** Extreme heat can damage your film, even if it is in a sealed package, and high humidity can cause corrosion and other damage to your camera. After the film pack has been placed in a camera, both the film and the camera can be damaged by excessive heat and humidity.

**Don't** remove film from its sealed bag until you are ready to use it.

**Don't** leave a loaded camera or packages of film in direct sunlight. Remember that the glove or luggage compartment of a car can get as hot as an oven. If you store film or a loaded camera in a

closet, keep it near the bottom where it's cooler.

If you live in a hot, humid climate, particularly if close to salt water, it would be advisable to write to Customer Service, Polaroid Corporation, Cambridge, Mass. 02139, and ask for the special instructions for the care of cameras and films in tropical climates.

**How to clean the lens:** Breathe on it to dampen the surface, then wipe it lightly with clean, dry absorbent cotton. **Never** use silicone coated eyeglass tissues. Clean the rangefinder windows in the same way.

## POSSIBLE PICTURE PROBLEMS

**White spots:** Some fairly large white spots scattered over the picture area usually indicate that you pulled the yellow tab out much too slowly. However, a large number of small white specks at one end of the picture usually are a sign that you pulled the yellow tab out much too fast.

It should take about as long to pull the yellow tab out as it takes to say "Pull it". Always pull the yellow tab out smoothly and steadily, without stopping or slowing down.

**Two yellow tabs out at same time:** You pulled two white tabs in a row without pulling a yellow tab. Both pieces of film will be ruined.

If you don't mind losing a third piece of film, the quickest way to correct this is to open the back door, remove the pack, pull the two jammed yellow tabs out of the spreader and discard those two films. Then replace the pack and close the back door. The next piece of film was light-struck

when you removed the pack, so pull both tabs and discard it.

You can save the third piece of film by the following procedure, which is more troublesome.

Grip both yellow tabs firmly, pull them both out together, and discard both pieces of film. This may cause developer to be spread around the inside of the camera back. Open the back of the camera and, without disturbing the film pack, remove the developer spreader. Carefully clean it, the yellow tab slot, and any other areas that need cleaning. (see page 22). **Never pull a white tab if you can see a yellow tab.**

**Overall bluish or reddish tint:** Pictures developed for too long a time will look blue overall. Pictures with a definite pink or reddish tint probably were not developed for the full recommended time. See the film instructions for details.



**Corner missing:** You pulled the yellow tab out at an angle instead of straight out. Always hold the camera by the flexible T handle when pulling the tabs out, and grip the yellow tab at its center, not at a side edge.

**Too dark:** The L/D control may have been turned toward DARKEN. Or, your film pack may carry a label with instructions to set the L/D control toward LIGHTEN for all pictures made with that pack. Flashcube variations may also cause a dark picture.



**Red eye:** Light from the flash is reflected from inside the eye. It can happen with adults but is more common with children. The chances of having red eyes can be reduced somewhat by having the subject look elsewhere than at the camera, and by shooting the picture in a well lit room (the pupils of the child's eyes will get smaller because of the bright room light).



**Oblong in print:** You didn't pull the white tab all the way out of the camera. When you pulled the yellow tab out, the white tab was dragged back into the camera and spoiled the picture. Always pull the white tab all the way out of the camera.



**Weak colors:** The picture was not developed for the full time given in the film instructions. If in doubt, it is better to develop the picture for slightly more than the recommended time than for too short a time. See the film instructions for details.



**Too light:** The L/D control may have been turned toward LIGHTEN. If the subject's image is very big and is not quite sharp, you were too close; use the rangefinder carefully, as shown on page 4.



**Too dark; out of focus:** You were too far away from the subject. Use the rangefinder carefully, as shown on page 4.

## KEEP THE SPREADER CLEAN

The developer spreader is the most important part of your camera. It must be kept clean, or you won't get good pictures. Signs that the spreader must be cleaned are: a yellow tab does not pop out when a white tab is pulled; or, there are developer chemicals on the back of a picture.

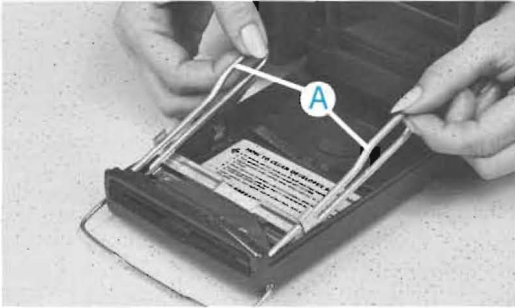

**1. Remove the spreader:** Use two hands and lift both steel loops (A) together. They are held by springs. The spreader will come out of the camera.

**Handle it carefully!** If you drop it, twist it, or otherwise handle it roughly, some of the parts may get bent and you will be unable to get good pictures. The camera will then have to go to a Polaroid repair station.

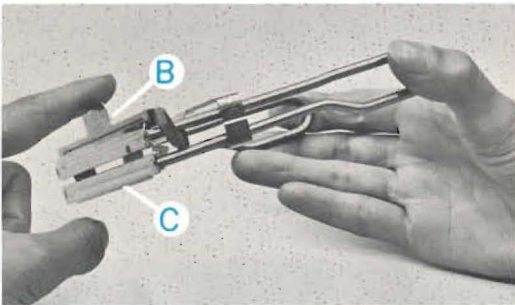

**2. Open the spreader bars:** Turn the spreader over so you see THIS SIDE DOWN. Lift the flat lever (B) marked LIFT TO OPEN. This opens the spreader bars (C).

**3. Wash, shake, wipe dry:** Hold the spreader under running water to clean out any developer chemicals that may be on it. Shake off the water, then wipe the parts dry with a lint-free cloth or tissue. Hold the spreader as shown above, so your fingers can't get caught, and push down the lever (B) to close the spreader bars.

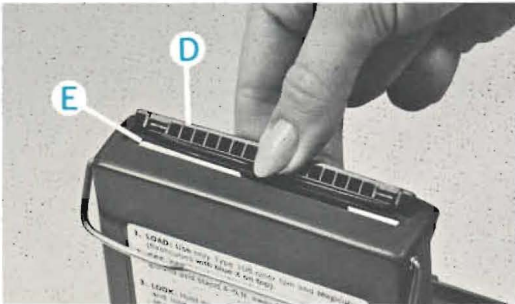

**4. Clean the tab slot:** If dirt collects here, the yellow tab can't pop out. Carefully open the narrow door (D) and clean it and the tab slot (E) with a damp cloth.

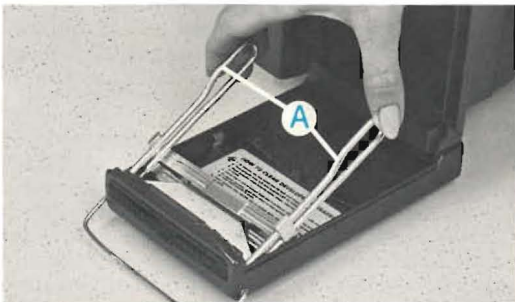

**5. Replace the spreader:** Turn it so THIS SIDE DOWN is down. Place the spreader in the camera back as shown and push the steel loops (A) down so they snap into place.

**Cleaning without water:** In an emergency you may be able to clean the spreader with cotton or cloth on a thin stick, such as a toothpick. This is not as good as washing and the spreader should be washed as soon as possible.

### IF NO WHITE TAB APPEARS AFTER PULLING OUT THE BLACK SAFETY COVER

If there's no white tab in the slot, do the following, away from bright light:

1. Unlock the back of the camera, open it part way and, without disturbing or moving the film pack, push the white tab (A) out into the open.

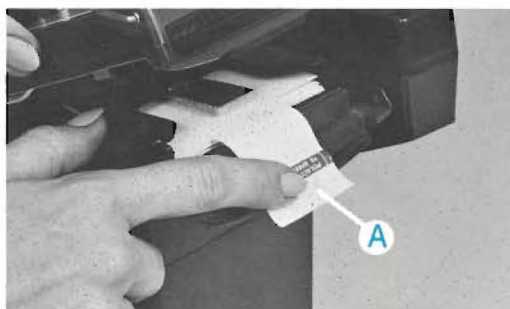

2. Close and lock the back of the camera, making sure that the white tab (A) is outside and behind the lock (B).

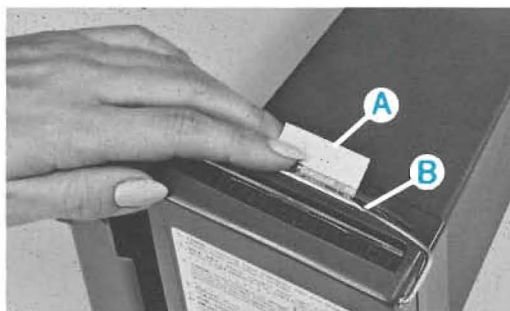

### IF NO YELLOW TAB APPEARS WHEN YOU PULL THE WHITE TAB, STOP!

**Don't** pull another white tab. Instead, do the following, away from bright light:

1. Carefully open the camera back without moving the pack and take hold of the yellow tab that failed to come out through the slot. You can use a pencil point to make sure the pack doesn't move.



2. Still being careful not to move the pack, gently pull the yellow tab all the way out of the camera and discard that piece of film. **Don't** try to save it.

3. While the back is open, **check that the developer spreader and the yellow tab slot are clean.** If necessary, clean them as shown on page 22.

4. Close and lock the camera back, making sure that the next white tab (A) is outside and behind the lock (B), as shown above.

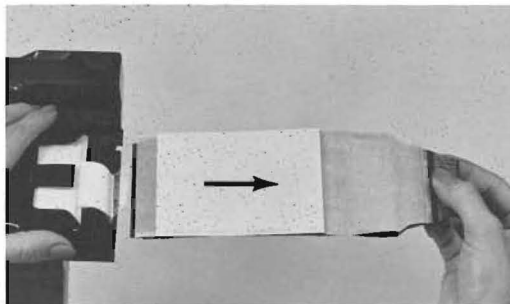

**DIRT IN THE SPREADER OR THE YELLOW TAB SLOT WILL BLOCK THE YELLOW TAB. BE SURE TO KEEP THEM CLEAN. SEE PAGE 22.**

### REMEMBER: YOU CAN OPEN A LOADED CAMERA, IF YOU DO IT CAREFULLY

If the camera is not in bright light, and if you don't move the film pack, you can open the camera back to adjust film tabs, or to clean the developer spreader (page 22). If you move the pack while the back is open, only one piece of film will be ruined; the rest will still be good.

## TO OBTAIN INFORMATION AND HELP

If you ever have a problem with the camera or film, or if you don't know whether or not a repair is needed, we urge you to seek help promptly to avoid film waste and disappointment. See your dealer or write to the nearest Polaroid office, or to Customer Service, Polaroid Corporation, Cambridge, Mass. 02139. **Or, call Customer Service collect at (617) 864-4568.** When writing, send sample pictures and, most important, **state what camera model you have.** Please be sure to include a clearly printed return address.

## WARRANTY

If this camera proves defective within one year of original purchase date, we will, at our option, repair or replace it free. We will make no charges for labor, "service," and parts, and incoming insured parcel post mailing costs will be refunded. We will also replace one pack of film to cover any pictures spoiled before the defect was identified.

The warranty does not cover damage caused by accident, misuse, or tampering with the camera. A charge will be made for such repairs.

To take advantage of the above warranty, the

camera must be returned to and repaired by a Polaroid Service Center or an Authorized Independent Repair Station (list available on request). For return instructions, see below.

## TO RETURN A CAMERA FOR REPAIR

To return your camera for repair, you may either ask your dealer to handle the return for you or you may mail the camera yourself. Pack it carefully (if you request it, we will send you a preaddressed shipping carton) to assure safe travel and send it by insured parcel post mail. Address it to the nearest Polaroid Service Center. (See list opposite for Polaroid Service Center addresses and for information about Authorized Independent Repair Stations.) If the camera is repaired under warranty, we will refund parcel post insured mailing costs when we ship back the repaired camera.

Whichever method you select, be sure to include a note describing the nature of the problem or sample pictures which illustrate it. If the problem concerns an accessory, such as a flash attachment, include it with the camera.

If you are near a Service Center, it may be more convenient for you to bring the camera in, instead of mailing it.

**CAUTION:** The Polaroid Land process uses a caustic jelly which is safely packed inside sealed containers within the metal-plastic pack. **If accidentally you should get some of this jelly on your skin, wipe it off immediately.** To avoid an alkali burn, wash the area with plenty of water as soon as possible. **It is particularly important to keep the jelly away from eyes and mouth.** Keep discarded materials out of reach of children and animals, and out of contact with clothing and furniture, as discarded materials still contain some jelly.

## POLAROID SERVICE CENTERS AND OFFICES

### CALIFORNIA

Polaroid Corp.  
875 Stanton Road  
Burlingame 94010

Polaroid Corp.  
2040 E. Maple Avenue  
El Segundo 90245

### GEORGIA

Polaroid Corp.  
3720 Browns Mill Road, S.E.  
Atlanta 30315

### ILLINOIS

Polaroid Corp.  
2020 Swift Drive  
Oak Brook 60521

### MASSACHUSETTS

Polaroid Corp.  
89 Second Avenue  
Waltham 02154

### NEW JERSEY

Polaroid Corp.  
P. O. Box 607  
W-95 Century Road  
Paramus 07652

### OHIO

Polaroid Corp.  
4640 Manufacturing Avenue  
Cleveland 44135

### TEXAS

Polaroid Corp.  
9029 Governors Row  
Dallas 75247

### PUERTO RICO

Polaroid of Puerto Rico, Inc.  
Charlyn Industrial Park  
Road 190, Km 1.7  
Carolina 00630

Mailing address:  
P. O. Box 2032, Ceramica Annex  
Carolina 00630

### AUSTRALIA

Polaroid Australia Pty. Ltd.  
2 Smail Street  
Ultimo, N.S.W. 2007

Mailing address:  
P. O. Box 335  
Broadway, N.S.W. 2007

### AUSTRIA

Polaroid GmbH  
Kegelgasse 27  
A-1035 Wien 3

### BELGIUM

Polaroid (Belgium) S.A.  
12-16 rue de la Victoire  
1060 Bruxelles

### CANADA

Polaroid Corp. of Canada, Ltd.  
350 Carlingview Drive  
Rexdale, Ontario

### ENGLAND

Polaroid (U.K.) Ltd.  
Office, Rosanne House  
Welwyn Garden City  
Hertfordshire  
Service Center  
Huggins Lane  
Welham Green, near Hatfield  
Hertfordshire

### FRANCE

Polaroid (France) S.A.  
57, rue de Villiers  
92-Neuilly sur Seine  
Service Center  
61, rue Chaptal  
92-Levallois

### GERMANY

Polaroid GmbH  
Königsbacher Strasse 15-21  
6 Frankfurt/Main-Niederrad 1

### ITALY

Polaroid (Italia) S.p.A.  
Viale Certosa 222  
20155 Milano

### JAPAN

Nippon Polaroid Kabushiki Kaisha  
Mori Bldg. No. 6  
32, Nishikubo Tomoe-cho  
Shiba, Minato-ku  
Tokyo

### MEXICO

Michelmex S.A.\*  
Apartado Postal #6-952  
Mexico 6 D.F.

### THE NETHERLANDS

Polaroid (Europa) N.V.  
Verkoopkantoor Nederland  
Office, Maassluisstraat 258  
P. O. Box 9167  
Amsterdam-W. III  
Service Center  
Markt 24  
Enschede

### NORWAY

Polaroid (Norge) A/S  
Hvamkrysset  
Boks 35  
2007 Kjeller

### SOUTH AFRICA

Frank & Hirsch (Pty.) Ltd.\*  
P. O. Box 1803  
Bree and Nugget Streets  
Johannesburg

### SWEDEN

Polaroid AB  
Box 20  
S-127 21 Skärholmen

### SWITZERLAND

Polaroid A.G.  
Hardturmstrasse 175  
Zürich 8037

\*Authorized Independent  
Repair Station

**Additional Repair Stations:** Besides Polaroid's own Service Centers listed here, there are several Authorized Independent Repair Stations in the U.S.A. and Canada. To locate the one closest to you, write to the nearest Polaroid Service Center or to Customer Service, Polaroid Corporation, Cambridge, Mass. 02139, or call Customer Service collect at (617) 864-4568.



**BIG SHOT**  
**PORTRAIT LAND CAMERA**  
**REGISTRATION CARD**

Date Camera Acquired \_\_\_\_\_

How was camera acquired? (Check one)

- 1  Store Purchase      4  Received as gift  
2  Mail Purchase      5  None of the above  
3  Military Exchange

I intend to use this camera for: (Check one)

- 1  Pleasure Only    3  Both Business and  
2  Business Only      Pleasure

Please describe the principal user of this camera:

Age: (Check one)

- 0  Under 10    2  20-29    4  40-49  
1  10-19      3  30-39    5  Over 50

Marital Status: (Check one)

- 1  Single      2  Married    3  Other

Last school completed by head of household:  
(Check one)

- 1  Grade School      3  College  
2  High School      4  Graduate School

Do you now or have you previously owned another Polaroid Land Camera?

- 1  Yes      2  No

If yes, which model? \_\_\_\_\_

- 1 Mr. \_\_\_\_\_  
2 Mrs. \_\_\_\_\_  
3 Miss \_\_\_\_\_  
(Please print)

Address \_\_\_\_\_

City \_\_\_\_\_ State \_\_\_\_\_

Zip Code \_\_\_\_\_ Telephone \_\_\_\_\_

Camera Serial Number \_\_\_\_\_

Thank you for completing this card.

P688 12/70

"Polaroid"®

Printed in U.S.A.

Affix  
Postage  
Stamp  
Here

Polaroid Corporation  
P.O. Box 18S  
Boston, Massachusetts 02118