

\$2.00

The first thirty years

1948  1978

A chronology of Polaroid photographic products

Produced for Customer Service, Polaroid Corporation, Cambridge, Mass. 02139 by  
Janice Blake  
Shelly Candidus  
John Wolbarst  
Design by Reed D. Harvey, Jr.

## ABOUT THIS CHRONOLOGY

In the 30-year span of this chronology, almost 80,000,000 Polaroid Land cameras were sold. There were more than 175 amateur and professional models. In addition, there have been a number of industrial products that make photographic records of various kinds.

This profusion of models falls into three main families, identified by the kind of film used — roll film, pack film, and SX-70 film — and each family represents an era in the history of Polaroid Corporation.

To provide the sensitized materials for these cameras and instruments, Polaroid marketed films in more than 40 sizes, types, and speeds.

The chronology presents the salient features of Polaroid's cameras, films, and other major photographic products. It gives the year and month in which the product was first marketed and the year in which it was discontinued as a product for sale.

In most cases the description of features has been limited to those needed to make a positive identification of the product and model. However, with some of the more important products a brief description of the functioning of the product has been included.

### Reference notes

1. Exposure numbers on roll film cameras. Each exposure number represents a precise amount of exposure provided by a specific shutter speed/lens aperture combination. No. 1 gives the maximum exposure (slowest shutter speed and widest lens aperture). Turning to No. 2 cuts the exposure in half. No. 3 gives half the exposure of No. 2 and so on.
- EV numbers. Later model roll film cameras and some pack film cameras are calibrated with EV (Exposure Value) numbers which have the same function as the exposure numbers used on earlier models. However, EV numbers are nine higher on the scale than exposure numbers giving equivalent exposures. Example: EV 10 on a Model 95B gives the same exposure as No. 1 on the earlier 95A.
2. Color response of black and white film. An orthochromatic black and white film does not record red light. A panchromatic black and white film records light of all colors, including red.
3. Film speed. The speed of a film is a measure of its sensitivity to light and is usually indicated by a number. The higher the number the "faster" the film and the more capable it is of making pictures in dim light. Polaroid Land film speed numbers are approximately equivalent to the ASA film speed numbers used with wet process films, although they are determined by different methods.
4. Film sizes. Unless described otherwise, all roll films (except color films) produce 8 reflection prints in one of two sizes. Print size of 40 Series films is approximately  $3\frac{1}{4} \times 4\frac{1}{4}$  in. (8.3 x 10.8 cm). Print size of 30 Series and Type 20 films is approximately  $2\frac{1}{2} \times 3\frac{1}{4}$  in. (6.3 x 8.2 cm). All film packs except SX-70 produce 8 prints in one of two sizes. 100/600 Series prints are approximately  $3\frac{1}{4} \times 4\frac{1}{4}$  in. (8.3 x 10.8 cm). 80 Series prints are approximately  $3\frac{1}{4} \times 3\frac{3}{8}$  in. (8.3 x 8.6 cm). SX-70 packs produce 10 prints with an image size approximately  $3\frac{1}{8} \times 3\frac{1}{8}$  in. (8 x 8 cm).
5. Lenses. All roll film cameras have 3-element lenses except the Pathfinder series (4-element) and the J66, J33, and The Swinger (single element). Lenses for pack film cameras may have one, two, three, or four elements and may be of either glass or plastic, depending on the camera model. All SX-70 cameras have 4-element glass lenses. Pronto! family cameras have 3-element plastic lenses and the simple OneStep has an aspheric single-element plastic lens.
6. Time exposures. All roll film cameras except the J66, J33, and The Swinger have settings for time exposures; so do all pack film cameras with manual shutter controls. Pack film cameras with automatic shutters can make automatic time exposures ranging from about 1 sec. to 30 sec., depending on the camera model.
7. SE (Special Edition) cameras have the same features as regular models but are sold under a five-year warranty. In addition, picture guarantee coupons are provided. The owner can return the appropriate number of unsatisfactory pictures (8 or 10 depending on film type) along with a coupon, and receive replacement film.
8. BC cameras are manufactured by Polaroid for K Mart Corp. and have the same operating features as regular models.
9. Sears Special cameras are manufactured by Polaroid for Sears, Roebuck and Co., and have the same operating features as regular models.



## Amateur Products

1948

November 1948–1953

**Model 95 Land camera.** 3-element lens, 135mm focal length, f/11–f/45. Shutter speeds 1/8–1/60. Exposure numbers<sup>1</sup> 1–8; single manual adjustment sets specific aperture and shutter speed combination. Folding optical viewfinder with aiming post on shutter housing. Earliest models featured coiled spring aiming post; later models had folding solid rod. Flash connection on lens board synchronized for flashbulbs only. Weight, about 4 pounds. This model was prototype for all Polaroid Land camera models produced during next 15 years. Uses 40 Series roll films.

November 1948–1950

**Type 40 Land film.**<sup>4</sup> Sepia tone roll film. Orthochromatic,<sup>2</sup> 60-second development time; coating not required. 100 speed.<sup>3</sup>

1950

May 1950–1959

**Type 41 Land film.**<sup>4</sup> First black and white roll film. Orthochromatic,<sup>2</sup> 60-second development time, coating required. 100 speed.<sup>3</sup>

1952

November 1952–1957

**Model 110 Land camera.** The Pathfinder. 4-element Wollensak Raptar lens, 127mm focal length, f/4.5–f/32. Coupled Kalart rangefinder. Shutter speeds 1–1/400 second. Uses 40 Series roll films.

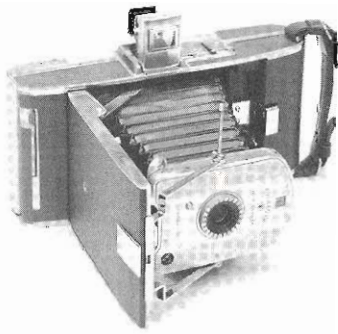

Model 95 Land camera

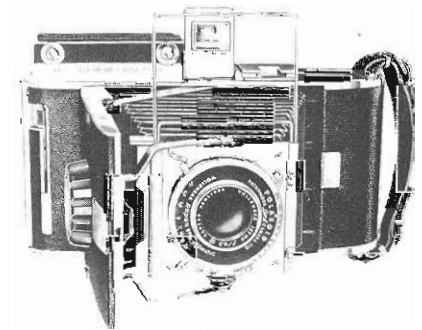

Model 110 Land camera

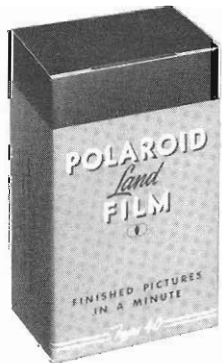

Type 40 Land film

## 1954

January 1954–1957

**Model 95A Land camera.** The Speedliner. Improved version of Model 95. Lens, 130mm focal length, f/8.8–f/35. Shutter speeds 1/12–1/100 second. Wire frame viewfinder on shutter housing instead of post and ball used on Model 95. Synchronized for both flashbulbs and electronic flash.

March 1954–1957

**Model 100 Land camera.** Similar to Model 95A except for special long-life roller bearings and heavy duty shutter designed for use in business and industrial applications. Black camera body rather than brown.

June 1954–1957

**Model 80 Land camera.** The Highlander. Smaller and lighter than Model 95. Lens, 100mm focal length, f/8.8–f/50; front element focusing. Shutter speeds 1/25–1/100 second; exposure numbers<sup>1</sup> 2–9. Viewfinder of Galilean optical type. Synchronized for flashbulbs only. Hot shoe flash connection on body. Uses 30 Series roll films.

June 1954–1958

**Type 31 Land film.** Similar to Type 41 but smaller, 2½ x 3¼ in. size.

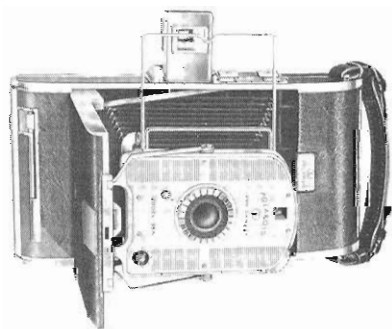

Model 95A Land camera

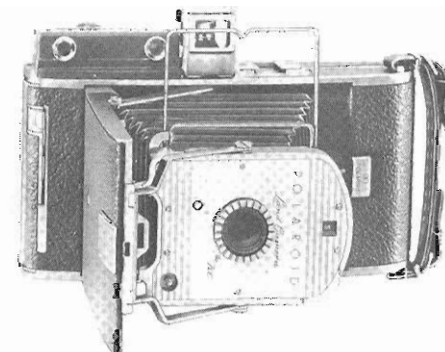

Model 700 Land camera

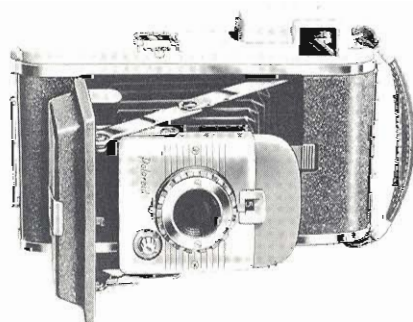

Model 80 Land camera

## 1955

April 1955–to date

**Type 42 Land film.**<sup>4</sup> First panchromatic<sup>2</sup> film. 60-second development time. 200 speed<sup>3</sup> when introduced.

April 1955–to date

**Type 32 Land film.** Similar to Type 42 but smaller, 2½ x 3¼ in. 60-second development time, 200 speed.<sup>3</sup>

September 1955–1958

**Type 43 Land film.**<sup>4</sup> Panchromatic.<sup>2</sup> Acetate base negative; produced prints of outstanding quality. 60-second development time. 200 speed.<sup>3</sup>

October 1955–1957

**Model 700 Land camera.** Similar to Model 95A but with built-in, non-coupled rangefinder of superimposed image type.

## 1956

May 1956–1963

**Type 44 Land film.**<sup>4</sup> Panchromatic.<sup>2</sup> 60-second development time. 400 speed.<sup>3</sup>



Type 42 Land film

### 1957

April 1957–1961

**Model 95B Land camera.** The Speedliner. Similar to Model 95A except shutter numbering system changed to EV10–17.<sup>1</sup>

April 1957–1959

**Model 80A Land camera.** The Highlander. Similar to Model 80 Highlander except shutter numbering system changed to EV11–18.<sup>1</sup>

May 1957–1960

**Model 150 Land camera.** Similar to Model 95B but with coupled rangefinder and parallax correcting viewfinder. Hot shoe flash connection on camera body instead of on shutter housing.

May 1957–1962

**Model 800 Land camera.** Similar to Model 150 except for specially selected shutter, helicoiled tripod insert, long-life roller bearings. Guide rails added to later models. Sold with 10-year guarantee.

### 1958

April 1958–1962

**Print Copiers.** Special illumination and lens system for copying Polaroid prints using standard Polaroid Land cameras and film.

**Print Copier Model 230.** For use with Model 80 series cameras

**Print Copier Model 240.** For use with Model 95 and similar cameras.

**Print Copier Model 2401.** For use with Model 110 and similar cameras.

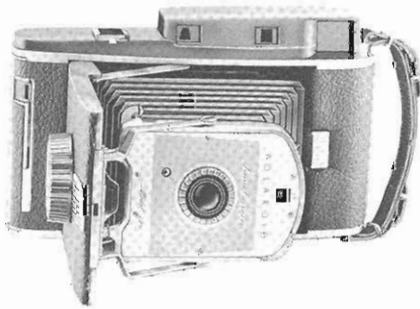

Model 150 Land camera



Model 110A Land camera

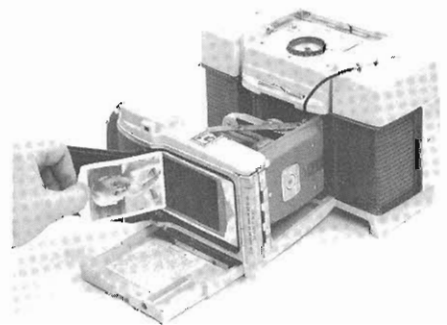

Print Copier Model 230 with Model 80A Land camera

## 1959

August 1959–to date

**Type 47 Land film.**<sup>4</sup> 3000 speed.<sup>3</sup>

Fastest available anywhere when marketed. Allows indoor pictures to be taken without flash. 60-second development time when introduced. Panchromatic.<sup>2</sup>

August 1959–1966

**Wink-Light #250, Wink-Light #252.**

Low-power repeating flash for making indoor pictures without flashbulbs. Made possible by development of 3000 speed film.

August 1959–1961

**Photoelectric shutter #440 and #440A.**

Fits over shutter of Model 150 and similar cameras providing aperture of f/54 for use with 3000 speed film. Electric eye automatically adjusts shutter speed for exposures from 1/10 to 1/800 second in daylight.

December 1959–1961

**Model 80B Land camera.** Same as 80A except for new type of cutter bar and independent film release switch under viewfinder housing.

December 1959–to date

**Type 37 Land film.** Similar to Type 47, but smaller, 2½ x 3¼ in. 3000 speed.<sup>3</sup>

**Type 32 Land Film.**<sup>4</sup> Speed increased to 400.<sup>3</sup>

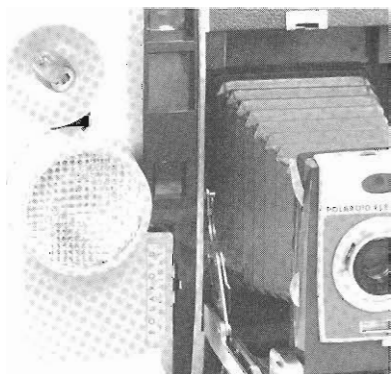

Wink-Light and auxiliary flasher



Photoelectric shutter # 440

## 1960

June 1960–1964

**Model 110B Land camera.** Similar to Model 110A except has single window combined rangefinder/viewfinder with projected frame system.

September 1960–1963

**Model 900 Land camera.** First automatic electric eye Land camera; powered by mercury battery. 3-element lens, 130mm focal length, f/8.8–f/82. Shutter speeds 1/12–1/600 second. Manual control EV10–22.<sup>1</sup> Synchronized for both flashbulbs and electronic flash. Single-window, coupled rangefinder/viewfinder. When used with automatic exposure control, camera is first set for proper film speed. Electric eye then measures light and computes proper shutter speed/aperture combination; exposure control is continuously variable over entire range of shutter speeds and apertures. Uses 40 Series roll films.

September 1960

**10-second development time** for all black and white film then in production; later extended to 15 seconds.



Model 110B Land camera

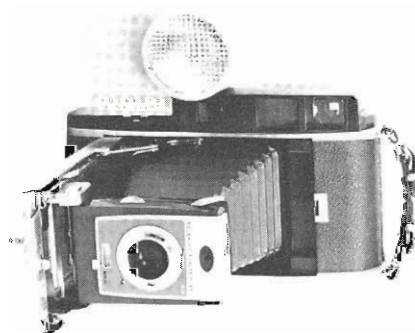

Model 900 Land camera

## 1961

January 1961–1963

**Model 850 Land camera.** Similar to Model 900 except has double-window viewfinder/rangefinder.

April 1961–1963

**Model J66 Land camera.** Simplified electric eye camera. Meniscus lens, 114mm focal length, f/19–f/64. Shutter speeds 1/15–1/1000 second. Exposure control is continuously variable over entire range of shutter speed/aperture combinations. Projected frame viewfinder. Built-in flashgun. Uses 40 Series roll films.

May 1961–1965

**Model 120 Land camera.** For international markets. Manufactured for Polaroid in Japan. Same as Model 110A except for Yashica lens, 127mm focal length, f/4.7–f/90, and Seikoska-SLV shutter, speeds 1–1/500 second, plus EV5–22,<sup>1</sup> self-timer.

September 1961–1963

**Model J33 Land camera.** Similar to J66 except smaller. Lens, 101mm focal length. Uses 30 Series roll films.

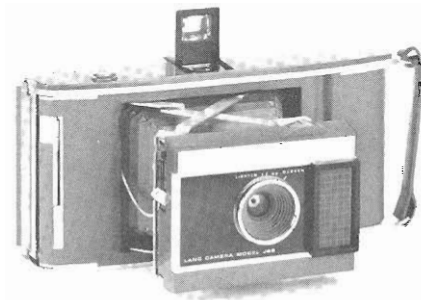

Model J66 Land camera

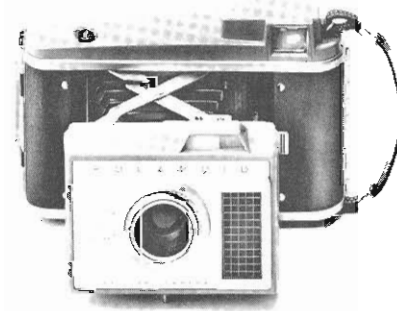

Model J33 Land camera



1962

May 1962–1965

**Model 160 Land camera.** For international markets. Manufactured for Polaroid in Japan. Same as Model 150.

1963

January 1963–1976

**Type 48 Polacolor Land roll film.**<sup>4</sup> 6 color prints. 60-second development time. 75 speed.<sup>3</sup>

January 1963–1969

**Type 38 Polacolor Land roll film.**<sup>4</sup> Similar to Type 48 except for smaller size.

July 1963

**100 Series pack film** introduced. New film format using flat, 8-exposure Land film pack. 3¼ x 4¼ in. prints. Simplified, rapid loading; pack drops into back of camera. Picture develops outside of camera.

July 1963

**100 Series Land cameras.** Use easy-loading, flat, 8-exposure Land film packs. These folding bellows cameras have electronic automatic exposure controls with either 6 or 2 separate lens aperture settings and either 4 or 2 film speed settings.

July 1963–to date

**Type 107 Land pack film.**<sup>4</sup> Black and white; 15-second development time. 3000 speed.<sup>3</sup>Panchromatic.<sup>2</sup>

July 1963–1976

**Type 108 Polacolor Land pack film.**<sup>4</sup> 60-second development time. 75 speed.<sup>3</sup> Replaced by Polacolor 2 Land film.

July 1963–1966

**Model 100 Land camera.** First fully automatic pack camera, designed for use with new pack film. 3-element lens, 114mm focal length. Basic apertures f/8.8 and f/42; also, f/35, 25, 17.5 and 12.5 for special purposes. Transistorized electronic shutter paired with battery-powered electric eye, which measures automatically exact amount of exposure required and provides continuously variable shutter speeds from 1/1200 second up to 10 seconds in low light. Automatically sets proper flash exposure. Synchronized for flashbulb only. Indoor black and white pictures without flash using 3000 speed<sup>3</sup> film. Four film speed settings. Two exposure ranges each for color and black and white. Coupled rangefinder and parallax-corrected projected frame viewfinder folds for compact carrying. Complete accessory capability, including portrait and close-up kits. Uses 100 Series pack films.



Type 107 Land film

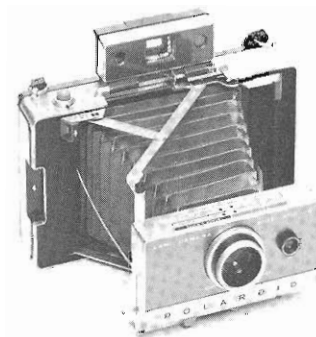

Model 100 Land camera



## 1964

July 1964–1967

**Model 101 Land camera.** Lower priced automatic pack camera. Similar to Model 100, but with only two film speed settings (3000 and 75) and two lens apertures (f/8.8, f/42). Single exposure range for color and black and white. Flash required for indoor pictures.

**Model 102 Land camera.** Special Markets version of Model 101.

## 1965

April 1965–1967

**Model 103 Land camera.** Similar to Model 101 but plastic body; no tripod socket.

**Model 135 Land camera.** Special Markets version of Model 103.

**Model 104 Land camera.** Similar to Model 103 but with 2-element plastic lens. Simplified "image sizer" range-finder combined with non-folding viewfinder. Plastic body and shutter housing. Limited accessory capability. Least expensive camera in pack line.

**Model 125 Land camera.** Special Markets version of Model 104.

July 1965–1970

**Model 20 Land camera.** The Swinger. Smallest, lightest (21 ounces), and least expensive Polaroid Land camera at time of its introduction. Plastic body and single-element plastic lens. Optical viewfinder. Exposure control semi-automatic, by built-in photometer. Exposure control knob is squeezed and turned; word YES appears clearly in viewfinder when correct exposure has been set. If clear YES does not appear, flashbulb is required. Built-in flash. Black and white pictures only. Uses Type 20 film.

**Model 415 Land camera.** Special Markets version of The Swinger Model 20.

**M15 Swinger Sentinel Land camera.** Special Markets version of The Swinger Model 20. Similar features except has separate flashgun that plugs into side of shutter housing.

July 1965–1970

**Type 20 Land film.** For Swinger cameras. Black and white. First roll film to develop outside camera. 8 prints, 2½ x 3¼ in.; 15-second development time. 3000 speed.<sup>3</sup>

November 1965–1969

**Model 180 Land camera.** Pack camera (manufactured in Japan) for advanced amateur and professional photography. Manual controls. 4-element Tominon lens, 114mm focal length, f/4.5–f/90. Seiko shutter, speeds from 1–1/500 second. EV5–22<sup>1</sup> Self-timer. Single-window Zeiss Ikon rangefinder/viewfinder. Can be used with Polaroid Model 281 flashgun or electronic flash. Automatic self-timer. Uses 100 Series pack films. Also uses 600 Series pack films introduced in 1977.

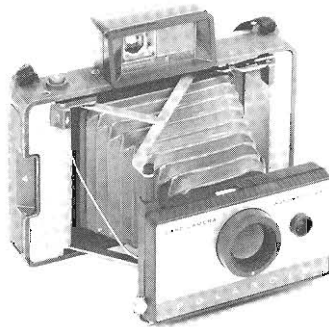

Model 104 Land camera

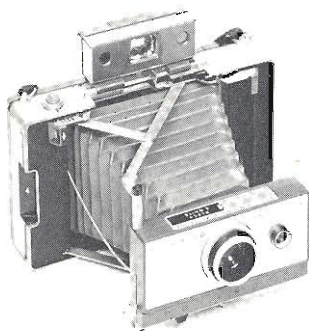

Model 101 Land camera



Model 20 Land camera (The Swinger)

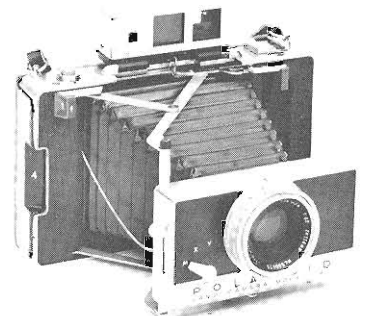

Model 180 Land camera

### 1967

January 1967–1969

**200 Series Land cameras.** Same basic features as 100 Series cameras except for different methods of designating film speed. Camera line extended. Improved shutters added to several lower priced cameras.

**Model 250 Land camera.** Similar to Model 100 except for Zeiss Ikon single-window combined rangefinder/viewfinder like that on Model 180. Uses every camera accessory available for automatic pack cameras.

**Model 240 Land camera.** Similar to Model 250 except for separate rangefinder/viewfinder windows. Complete accessory capability.

**Model 230 Land camera.** Similar to Model 240 except for plastic body. No tripod socket.

**Model 220 Land camera.** Similar to Model 230 except for 2-element plastic lens and non-folding rangefinder/viewfinder. Limited accessory capability.

**Model 210 Land camera.** Similar to previous Model 104. Lowest priced and lightest (37½ ounces) pack camera.

### 1968

February 1968–1970

**Model 225 Land camera.** Special Markets version of Model 220.

**Model 215 Land camera.** Special Markets version of Model 210.

April 1968–1970

**Model 3000 Land camera.** The Big Swinger. Rigid plastic body similar to that of The Swinger, except that back of camera is designed to accept standard Type 107 pack film. Same lens and exposure control system as Swinger Model 20. New developer spread system utilizing fixed metal spreader bars instead of rollers. Lightest weight (only 17 ounces) Polaroid Land camera at time of its introduction.

### 1969

February 1969–1971

**300 Series Land cameras.** Except for Model 360, same basic features as 200 Series, plus built-in development timers on most models.

**Model 360 Land camera.** First camera to have electronic flash unit with automatic flash exposure control coupled to camera's rangefinder. Effective flash range, 3½–8 ft. for both color and black and white. Rechargeable nickel-cadmium battery in flash unit; fast charger supplied with camera. Rest of camera similar to Model 250 except:

- (1) Has electronic development timer that starts automatically when yellow film tab is pulled out of camera.
- (2) Improved shutter has greatly extended time exposure range.
- (3) Smallest lens aperture is f/60 instead of f/42 as in rest of 300 Series.

**Model 350 Land camera.** Similar to Model 250 except for automatic electronic development timer (same as on Model 360) and improved shutter.

**Model 340 Land camera.** Similar to Model 230 except for built-in mechanical development timer. Complete accessory capability.

**Model 330 Land camera.** Same body and lens as Model 340, but has only two film speed settings, two lens apertures (f/8.8, f/42), single exposure range for color and black and white, and non-folding rangefinder/viewfinder. Built-in mechanical development timer. Limited accessory capability.

**Model 320 Land camera.** Similar to Model 330 but has 2-element plastic lens instead of glass triplet lens; no built-in development timer. Lowest priced folding pack camera. Limited accessory capability.

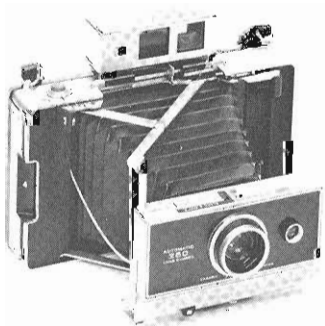

Model 250 Land camera



Model 3000 Land camera (The Big Swinger)

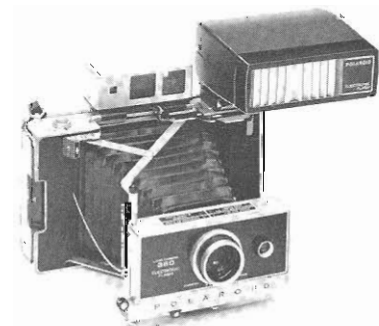

Model 360 Land camera and electronic flash

February 1969–1972

**Colorpack II Land camera.** First in long line of non-folding plastic bodied automatic cameras for pack film. First in low price range (under \$30) that makes both color and black and white pictures. Camera body, viewfinder, and developer spread system similar to Big Swinger. Electric eye exposure controls and shutter similar to Model 320. Unique 114mm semi-telephoto triplet lens (originally glass, later plastic) is focused by turning front element; two apertures, f/9.2 and f/58. Simplified single distance (5 ft.) rangefinding device in viewfinder. Uses flashcubes in spring-motored, automatically rotating socket.

February 1969–1971

**Colorpack IV Land camera.** Special Markets version of Colorpack II. Mechanical development timer on side.

February 1969–1971

**Model 315 Land camera.** Special Markets version of Model 320. Has image sizer rather than split-image rangefinder.

**Model 325 Land camera.** Special Markets version of Model 210.

June 1969–1971

**Model 335 Land camera.** Special Markets version of Model 330. Electronic development timer.

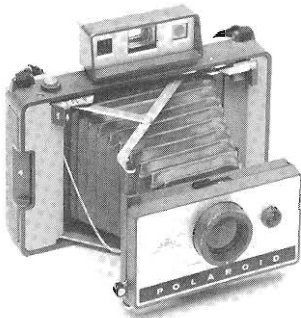

Model 320 Land camera

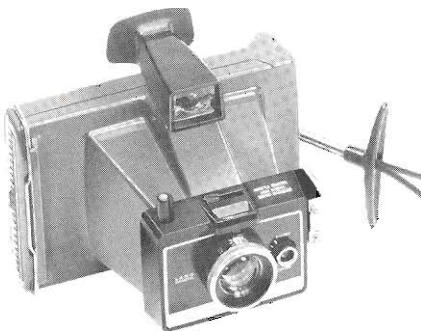

Colorpack II Land camera

## 1970

February 1970–1971

**Colorpack M6 Land camera.** Similar to Colorpack II with addition of built-in mechanical development timer.

March 1970–1970

**Countdown M80 Land camera.** Special Markets version of Model 330.

March 1970–1977

**Countdown M60 Land camera.** Special Markets version of Model 210 with addition of built-in mechanical development timer.

April 1970–1971

**Colorpack III Land camera.** Similar to Colorpack II except has:

- (1) Built-in mechanical development timer.
- (2) Triangulation type Distance Finder. User tips camera forward to place horizontal red line in viewfinder over point on ground directly below subject's face, presses button on Distance Finder, causing pendulum to swing forward, then releases button, locking pendulum. Distance Finder scale then shows distance from camera to subject. First few cameras produced did not have Distance Finder.

November 1970–to date

**Type 20C Land film.** 8-exposure film rolls; 2½ x 3¼ in. prints. For Swinger cameras. First coaterless black and white Land film. Surface of print quickly dries to provide protective finish. Although similar to Type 20 in overall appearance, Type 20C is totally different chemically and photographically and provides prints with improved image structure and tonal range. 30-second development time. 3000 speed.<sup>3</sup>



Type 20C Land film

## 1971

March 1971

**400 Series Land cameras.** Similar to 300 Series except for new type of flash exposure system utilizing only G.E. Hi-Power flashcubes or equivalent in Polaroid Focused Flash unit. Plugging in flash unit automatically sets shutter to single constant speed. Focused Flash unit is coupled to rangefinder system. As camera is focused, vertically moving louvers in front of flashcube automatically open or close to provide correct exposure. Flash range 3½–10 ft

March 1971–1974

**Model 450 Land camera.** Similar to Model 350 except for flash system.

March 1971–1976

**Model 440 Land camera.** Similar to Model 340 except for flash system

March 1971–1977

**Model 430 Land camera.** Similar to Model 330 except for flash system.

**Model 420 Land camera.** Similar to Model 320 except for flash system.

March 1971–1973

**Countdown 90 Land camera.** Special Markets version of Model 430. Automatic electronic development timer.

**Countdown 70 Land camera.** Special Markets version of Model 420. Built-in mechanical development timer.

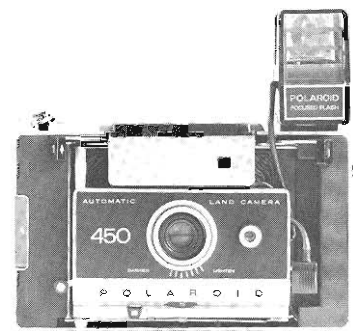

Model 450 Land camera and Focused Flash



1971 (continued)

March 1971–1973

**Big Shot Portrait Land camera.** Unique fixed-focus camera designed to make only flash color portraits of one or two people at one distance — approximately 39 inches. Light source is Magicube behind plastic diffuser. Single meniscus lens, 220mm, f/29; single speed shutter. Camera is focused by moving back and forth until two images of subject coincide in one-distance rangefinder/viewfinder. Uses only Type 108 film. Originally sold with fixed bar spread system. Later cameras have mini-rollers

March 1971

**80 Series pack films.** Print size is approximately 3¼ x 3⅜ in. Eight exposure packs designed for use in new series of "square format" compact plastic-bodied cameras similar to Colorpack family except for size. Although 80 Series films were manufactured in U.S.A., they were introduced in international markets prior to domestic introduction.

March 1971–to date

**Type 87 Land film.**<sup>4</sup> 80 Series version of Type 107 black and white film. Prints do not need to be coated. Development time, 30 seconds. Speed, 3000<sup>3</sup>.

March 1971–1976

**Type 88 Polacolor Land film.**<sup>4</sup> 80 Series version of Type 108 color film. Replaced by Polacolor 2 Land film.

March 1971–1976

**Colorpack 80 Land camera.** For international markets. First camera to take both Type 87 black and white and Type 88 Polacolor film. Similar to Colorpack II except:

- (1) Body scaled down for 80 Series film packs.
- (2) No diffuser in front of flashcube. Early production models equipped with spreader bars; later models have mini-rollers.

March 1971–1975

**Colorpack 82 Land camera.** For international markets. Similar to Colorpack 80 with addition of development timer.

**Colorpack 85 Land camera.** For international markets. Similar to Colorpack 82.

**Colorpack 88 Land camera.** For international markets. Similar to Colorpack 80 except takes only Type 88 Polacolor film.

March 1971–1975

**Zip Land camera.** For international markets. Similar to Model 3000, Big Swinger, except has smaller body for Type 87 black and white film only. Manufactured in United Kingdom and marketed internationally until September, 1974, when it was introduced in U.S.A.

May 1971–1972

**Super Colorpack Land camera.** Similar to Colorpack II but has novel systems for measuring distance and controlling flash exposure. Distance Finder in viewfinder consists of horizontal black line mounted on pivoting pendulum and vertically movable red arrow actuated by turning lens ring. User looks through viewfinder, tips camera front down and aims black line at point on ground directly below subject's face, then turns lens ring to place red arrow over black line. This causes camera to automatically set lens for that distance. Focused Flash system uses only G.E. Hi-Power flashcubes or equivalent. As lens is turned to match red arrow and black line of Distance Finder, horizontally moving louvers in front of flashcube automatically open or close to give correct flash exposure within 3½–10 ft. range. First production had fixed bar developer spread system; later models have mini-rollers.

June 1971–1972

**Super Colorpack IV Land camera.** Special Markets version of Super Colorpack.

June 1971–1972

**Square Shooter Land camera.** First camera sold in U.S.A. to use Type 88 Polacolor film. Except for film size, similar to Super Colorpack. Color pictures only.

December 1971

**Mini-roller developer spread system.** Provides low-priced plastic-body cameras with lightweight, simplified version of steel roller developer spread system used in folding pack cameras. Replaced, and is interchangeable with, fixed bar spread system used in early production of rigid body plastic pack cameras.

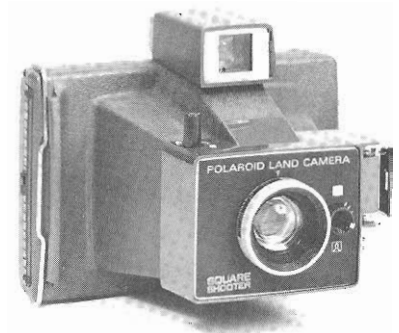

Square Shooter Land camera

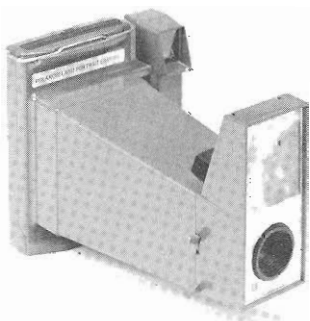

Big Shot Land camera



Super Colorpack Land camera

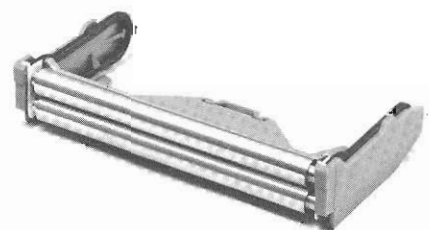

Mini-rollers

## 1972

February 1972–1975

**Square Shooter 2 Land camera.** Similar to Colorpack 80 except takes only Type 88 color film.

September 1972–1975

**Square Shooter 4 Land camera.** Special Markets version of Square Shooter 2. Built-in mechanical development timer.

October 1972–to date

**SX-70 Land System.** Totally new approach to photography incorporating several revolutionary concepts: self-contained, self-developing film and completely automated folding single lens reflex camera with extraordinary optical and mechanical features designed to remove barriers between photographer and subject. Photographer simply focuses and shoots; developing picture is ejected automatically.

**SX-70 Land film.** Ten-exposure film pack. Image size, approximately  $3\frac{1}{8} \times 3\frac{1}{8}$  in. Important features are:

- (1) Each film unit consists of color negative and positive print sheet made of transparent plastic held in close contact by edge tape, plus pod of processing reagent.
- (2) Each film pack contains special flat battery to provide power for camera to take 10 pictures with that pack.
- (3) Camera ejects each exposed film unit automatically, starting development process as it does so.
- (4) Image develops on underside of positive sheet, thus is protected by tough, flexible plastic layer.
- (5) Picture can be observed developing, even in broad daylight. This is made possible by opacifying component of reagent. When film is first ejected, image area is blue-green; as processing proceeds, image appears, faintly at first and then more clearly as opacifier color lessens and finally disappears. Processing stops automatically.

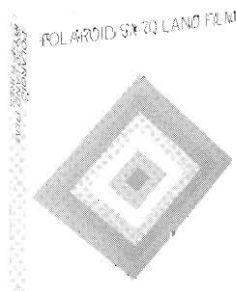

SX-70 Land film

(6) All parts of film unit are utilized for each picture; there is nothing to peel apart, only empty pack is discarded after 10 pictures.

(7) Dyes are strongly resistant to fading.

(8) Speed, approximately  $150^3$ .

(9) Development time, several minutes.

October 1972–1977

**SX-70 Land camera (Deluxe model).** Folding single-lens reflex camera powered by special flat battery in SX-70 film packs. Important features:

(1) Automation. User merely focuses and presses shutter button; camera automatically ejects developing picture.

(2) Optical system. Four-element glass lens. Focuses down to 10.4 in.; with close-up lens to  $5\frac{1}{2}$  in. for life-size images. Focal length, 116mm; maximum aperture,  $f/8$ . Image for viewing travels to eye through system of several mirrors and lenses, some aspheric. User turns focus wheel (and front element of lens) to get sharpest image on viewing screen. Cameras produced after October, 1973, equipped with split circle focusing aid on viewing screen.

(3) Exposure controls. Two horizontally gliding blades act as both shutter and diaphragm, are controlled by electric eye. Exposures range from  $1/175$  second and  $f/22$  in brightest light to  $1/20$  second and  $f/8$  in dim light; also, automatic time exposures up to 14 seconds. Minimum aperture is  $f/96$  in early models and  $f/74$  later.

(4) Flash. Camera takes 10-bulb flash-bar arrays. Inserting array sets single shutter speed; focusing then controls exposure automatically by adjusting size of aperture according to subject distance over range from 20 ft. to 10.4 in.

(5) Brushed chrome and brown leather finish.

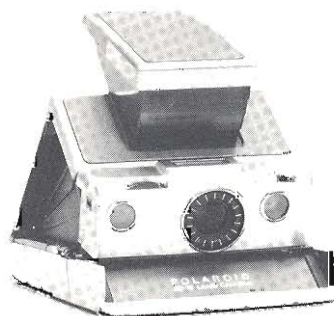

SX-70 Land camera (Deluxe model)

## 1973

April 1973–1975

**The Colorpack Land camera.** Similar to Colorpack II except:

(1) Has mini-rollers instead of fixed bar spread system.

(2) Shutter modified to permit use of either regular flashcubes (4–8 ft. range) or G.E. Hi-Power flashcubes or equivalent (4–12 ft. range).

September 1973–1975

**Colorpack 5 Land camera.** Special Markets version of The Colorpack. No development timer.

1974

February 1974–1976

**Model 195 Land camera.** U.S. made body, Japanese lens and shutter. Assembled in U.S.A. Similar to Model 180 except has:

- (1) 4-element Tomionon lens, 114mm, f/3.8. – f/64.
- (2) Viewfinder/rangefinder made by Polaroid has separate windows.
- (3) Built-in mechanical development timer.

Uses 100 Series pack films. Also uses 600 Series pack films introduced in 1977.

**Model 195 SE Land camera.**<sup>7</sup>

April 1974–1977

**Model 190 Land camera.** U.S. made body, Japanese lens and shutter assembled in Japan for international markets. Similar to Model 195 except:

- (1) Zeiss Ikon single-window combined rangefinder/viewfinder.
- (2) Automatic electronic development timer.

September, 1974

**SX-70 Land camera.** Improved flash exposure system compensates for minor focusing inaccuracies.

September, 1974–to date

**Type 87 Land film** marketed in U.S.A.

September, 1974–1977

**Zip Land camera** marketed in U.S.A.

September 1974–1977

**SX-70 Model 2 Land camera.** Less expensive version of Deluxe SX-70. Same electronics and optics. White plastic body finished in brown Porvair.

1975

January 1975–1976

**Colorpack 100 Land camera.** For international markets. Similar to The Colorpack.

January 1975–1976

**Model 455 Land camera.** For international markets. Similar to Model 440 except has metal body and tripod mount.

February 1975–1977

**SX-70 Executive Land camera.** Special Markets version of SX-70 Deluxe model.

**SX-70 Land camera BC.**<sup>8</sup>

**Super Shooter Land camera.** Similar to The Colorpack with modifications allowing it to take 5 types of film in two sizes (107, 108, 105, 87, 88). Viewfinder adjusts automatically to film format (square or rectangular).

**Super Shooter SE Land camera.**<sup>7</sup>

**Super Shooter Plus Land camera.** Similar to Super Shooter with addition of built-in development timer. Sold with carrying case.

February 1975–to date

**The Clincher Land camera.** Special Markets version of Super Shooter.

February 1975–to date

**Type 108 Polacolor 2 Land film.** Brilliant and completely new Polacolor film made with same metallized dyes used in SX-70 film. New color negative and new positive sheet. Anti-curl photographic paper; print mounts no longer needed. Because of dye stability, pictures are extremely fade resistant. 75 speed.<sup>9</sup> Interchangeable with Type 108.

February 1975–1977

**SX-70 Model 2 Executive Land camera.** Special Markets version of SX-70 Model 2.

February 1975–to date

**Model 355 Land camera.** For international markets. Similar to Model 340 except for metal body and tripod mount.

March 1975–1978

**Super Swinger Land camera.** For international markets. Similar to Zip.

March 1975–1978

**Colour Swinger Land camera.** For international markets, primarily U.K. Similar to Square Shooter II with added neckstrap.



Zip Land camera



Model 195 Land camera

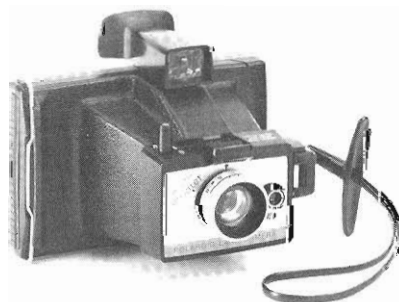

Super Shooter Land camera

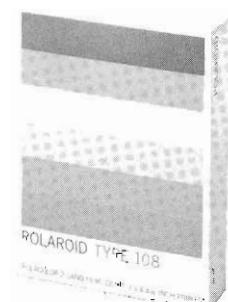

Polacolor 2 Land film



## 1976

March 1975–to date

**Colour Swinger II Land camera.** For international markets, primarily U.K. Similar to Square Shooter II with added neckstrap and timer.

March 1975–1977

**Super Colour Swinger Land camera.** For international markets, primarily U.K. Similar to Colorpack 80 with added neckstrap and tripod socket.

March 1975–1978

**Super Colour Swinger II Land camera.** For international markets, primarily U.K. Similar to Colorpack 80 with added timer, neckstrap, and tripod socket.

September 1975–1978

**SX-70 Model 3 Land camera.** Least expensive folding SX-70 camera. Galilean type viewfinder; set-distance focusing. Otherwise, similar to SX-70 Deluxe and Model 2. Black plastic and brown Porvair finish.

September 1975–1978

**Electric Zip Land camera.** Similar to Square Shooter 2 with capability to take black and white pictures as well as color. Low-priced camera available in three colors — red, white, and blue.



SX-70 Model 3 Land camera



Electric Zip Land camera

January 1976–1978

**Swinger EE Land camera.** For international markets. Similar to Zip Land camera in that it takes only Type 87 black and white film. However, has electric eye rather than photometer exposure system. Also has neckstrap and plastic foot, which helps support camera for time exposures.

January 1976–1977

**EE22 Land camera.** For international markets. Similar to Swinger EE.

**EE33 Land camera.** For international markets. Similar to Square Shooter II with added foot and neckstrap.

**EE44 Land camera.** For international markets. Similar to Electric Zip with added neckstrap and foot.

**EE55 Land camera.** For international markets. Similar to Super Shooter except takes only color pictures and has tripod socket.

**EE60 Land camera.** For international markets. Similar to Super Shooter with added neckstrap and tripod socket.

**EE66 Land camera.** For international markets. Similar to Super Shooter Plus with added neckstrap and tripod socket.

January 1976–1978

**Super Colour Swinger III.** For international markets, primarily U.K. Similar to Super Shooter with added neckstrap and tripod socket.

February 1976–1977

**SX-70 Land Camera SE.**<sup>7</sup>

March 1976–1977

**Pronto! Land camera.** Non-folding camera for SX-70 pictures. Galilean-type viewfinder. Set-distance focusing. Electronic module calculates exposures, setting both lens opening and shutter speed. Focuses from 3 ft. to infinity. Flash range 3 ft. to 12 ft. 3-element, 116mm plastic lens; variable aperture f/9.4–f/22. Automatic time exposures to one second. Uses flashbar arrays.

**Pronto! S Land camera.** Special Markets version of Pronto!

**Pronto! SM Land camera.** Special Markets version of Pronto!

**Pronto! SE Land camera.**<sup>7</sup>

**Pronto! Plus Land camera.** Sold with film, flashbar, carrying case and pocket album.



Pronto! Land camera

1976 (continued)

March 1976

**SX-70 Land film** was improved. Several significant changes were made, including increased processing temperature latitude and glare-reducing surface.

March 1976–to date

**Type 88 Polacolor 2 Land film.** Square format film incorporating Polacolor 2 film technology.

March 1976–to date

**EE88 Land camera.** For international markets. Similar to Square Shooter II.

**Model 2000 Land camera.** For international markets. Similar to Pronto!

September 1976–to date

**Super Clincher Land camera.** Special Markets version of Pronto!

**Clincher 2 Land camera.** Special Markets version of Super Shooter Plus with modification to film selector featuring option of indoor pictures without flash when using Type 107, 3000 speed<sup>3</sup> film. Batteries packed separately.

October 1976

**SX-70 Land camera** improved to incorporate flash inhibit when film pack is empty, picture inhibit when there are no fresh flashbulbs.

1977

January 1977–to date

**Model 1500 Land camera.** For international markets. Similar to Pronto!B (see March 1977 entry).

**Model 3000 Land camera.** For international markets. Similar to Pronto!RF (see March 1977 entry).

**Polatronic Flash.** For international markets. Electronic flash unit designed for use with Models 1500, 2000, and 3000.

January 1977–1978

**EE38 Land camera.** For international markets. Similar to Square Shooter II with added foot and neckstrap; mechanical development timer.

**EE58 Land camera.** For international markets. Similar to Minute Maker with added tripod socket.

January 1977–to date

**EE100 Land camera.** For international markets. Similar to The Reporter but without extended range feature (see March 1977 entry).

March 1977–to date

**SX-70 Alpha 1 Land camera.** Similar to SX-70 Land camera, Deluxe model, with several new electronic features, including fill-flash capability. Neckstrap and tripod socket. (Some early models were called SX-70 Alpha Land camera.)

**SX-70 Alpha SE Land camera.**<sup>7</sup>

**SX-70 Alpha Land camera, Sears Special.**<sup>9</sup>

**SX-70 Alpha Executive Land camera.** Special Markets version of SX-70 Alpha 1.

**SX-70 Alpha Model 2 Land camera.** All features of SX-70 Alpha 1 except has black plastic and brown Porvair finish.

**Pronto! B Land camera.** Similar to Pronto! Brushed silver and black matte finish.

**Pronto! RF Land camera.** Similar to Pronto! with added coincident-image rangefinder.

**Pronto! RF SE Land camera.**<sup>7</sup>

**Pronto! BC Rangefinder Land camera.**<sup>8</sup>

**Pronto! Land camera, Sears Special.**<sup>9</sup>

**Pronto! RF Land camera, Sears Special.**<sup>9</sup>



Polatronic flash

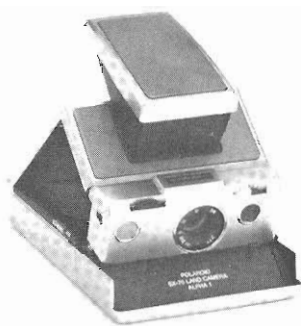

SX-70 Alpha 1 Land camera



Pronto! RF Land camera

March 1977–1978

**Pronto! Extra Land camera.** Similar to Pronto! Sold with self-timer and tripod mount.

March 1977–1977

**Encore! Land camera.** Special Markets version of Pronto! Sold with vinyl carrying case.

March 1977–to date

**MinuteMaker Land camera.** Similar to Super Shooter; however, takes only color pictures.

**MinuteMaker BC Land camera.**<sup>8</sup>

March 1977–1978

**MinuteMaker Plus Land camera.** Similar to Super Shooter Plus.

**MinuteMaker Plus SE Land camera.**<sup>7</sup>

March 1977–to date

**The Reporter Land camera.** Folding, plastic body camera for pack film pictures. Has Polaroid Polatriplet plastic lens, 114mm, f/9.2, electric eye, electronic shutter. Special lighting selector setting, 3000ER (extended range) allows taking indoor pictures without flash when using 3000 speed<sup>3</sup> film. Bright-frame viewfinder. Tripod and cable release sockets.

**The Reporter SE Land camera.**<sup>7</sup>



MinuteMaker Land camera

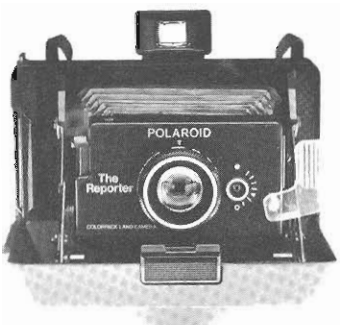

Reporter Land camera

July 1977–to date

**OneStep Land camera.** Simplest, least expensive camera for SX-70 pictures. Single-element plastic lens 103mm, f/14.6 prefocused to give sharp pictures from 4 ft. to infinity. Automatically variable aperture and shutter speed controlled by electric eye. Flash range 4–8 ft. Flash will not fire if camera is out of film. Lightweight (15 oz.).

**OneStep SE Land camera.**<sup>7</sup>

**OneStep Land camera, Sears Special.**<sup>9</sup>

March 1977–1978

**Colorpack 200 Land camera.** For international markets. Similar to MinuteMaker Plus with added tripod socket.

September 1977–to date

**Model 1000 Land camera.** For international markets. Similar to OneStep



OneStep Land camera

## 1978

January 1978–to date

**Instant 10 Land camera.** For international markets. Similar to Square Shooter II with added foot and neckstrap.

**Instant 20 Land camera.** For international markets. Similar to Electric Zip with added neckstrap and foot.

**Instant 30 Land camera.** For international markets. Similar to MinuteMaker Plus with added tripod socket. Also similar to Colorpack 200.

February, 1978–to date

**Pronto! BC Land camera.**<sup>8</sup>

March 1978–to date

**Presto! Land camera.** Special Markets version of OneStep.

March 1978–to date

**OneStep BC Land camera.**<sup>8</sup>

March 1978–1978

**MemoryMaker Land camera.** Special Markets version of Minute Maker.

May 1978

**Polavision Land system.** Revolutionary and remarkably easy to use system which allows for filming and viewing motion pictures in minutes. System consists of camera, self-developing film called Phototape, and Player in which Phototape cassette is processed automatically and then viewed.

May 1978–to date

**Polavision Land camera.** Instant motion picture camera with single-lens reflex viewing. 8-element lens, f/1.8-22 (12.5mm–25mm) with 2:1 zoom. Electric eye provides automatic exposure control. Near/Far distance setting for focus. Special indicators signal low light situations and when to start and finish shooting. Weight, 26½ oz. Pistol grip.

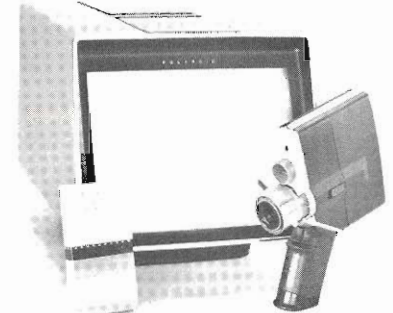

Polavision Land camera, cassette and player



1978 (continued)

**Polavision Land Player.** Self-contained, rear-projection viewer for processing and showing instant movies. Phototape is automatically processed within about 90 seconds after being dropped into slot on top of unit. Shows developed Phototape cassettes instantly. Portable, tabletop unit weighs 24 lbs. Leatherette finish.

**Polavision Phototape Cassette.** Self-contained cassette of color Phototape film. Develops automatically in Player. Playing time about 2½ minutes. Rewinds and plays automatically.

**Polavision TwiLight.** Lightweight (4 oz.) lighting unit consisting of two bulbs and reflectors, which plugs into Polavision camera. Range of TwiLight is 6 ft. to about 10 ft. Color balanced for Phototape cassettes.

**Polavision Instant Replay Control.** Plugs into Polavision Player to allow replaying of any portion of Phototape.

May 1978—to date

**Tele 1.5 Lens #119.** Snaps onto SX-70 cameras. Enlarges images by 50 percent.

May 1978—to date

**Type 107C Land film.** <sup>4</sup>Black and white prints do not need to be coated. 30-second development time <sup>3</sup>3000 speed

July 1978

**SX-70 film.** Improvements were made in chemistry of SX-70 film which cut in half time required for picture development.

July 1978—to date

**SX-70 Sonar OneStep Land camera.** Features automatic and precise focusing in any lighting conditions by means of ultrasonic echoing device. Camera's transducer measures distance to subject by calculating amount of time it takes sound waves to reach subject and return. Transducer is integrated with camera's electronic circuitry. As shutter button is pressed, lens automatically moves to correct position for accurate focus and exposure. By pressing shutter button only part way, user can preview picture. In addition to sonar focusing, camera has all features of SX-70 Alpha 1. Camera can be focused manually if desired. Built-in low-light indicator. Chrome and black leather finish.

**Pronto! Sonar OneStep Land camera.** Sonar focusing system similar to that on SX-70 Sonar OneStep, but without previewing capability. Built-in low-light indicator. Variable aperture from f/10.6 to f/24. Camera has all other features of Pronto! B, plus built-in tripod socket.

**Tele 1.5 Lens #124.** Similar to #119, modified for SX-70 Sonar OneStep Land camera and other SX-70 models.

September 1978—to date

**Model 600 Land camera.** For international markets. Rugged, diecast aluminum construction, interchangeable film holders with dark slides, 127mm fixed lens. Manual exposure settings. Shutter synchronized for electronic flash. Makes use of full line of Polaroid professional pack film types (see Professional/Industrial products).

**Model 600SE Land camera.** Same as Model 600 but features three interchangeable lenses: 127mm, wide angle, and telephoto. Each lens equipped with Seiko between-lens shutter, with 10 speeds ranging from 1 second to 1/500 second and "B" (Not Special Edition camera.)

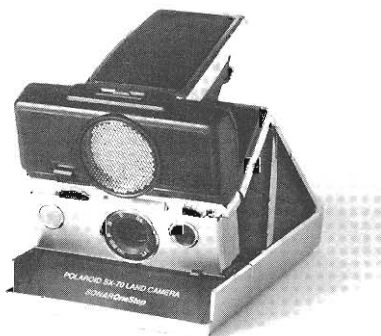

SX-70 Sonar OneStep Land camera

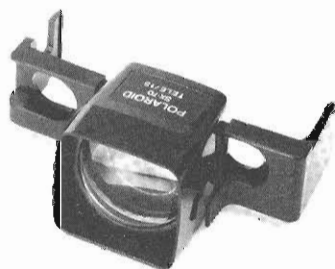

Tele 1.5 Lens # 119



Pronto! Sonar OneStep Land camera



Model 600 SE Land camera and lenses

1951

1951-1978

**Land camera roll film back.** Adapts professional cameras and various types of industrial and scientific instruments for use with Polaroid Land roll films. Originally introduced as Model 95 Land roll film back. Modified slightly in 1963 and designated CB-40 Land camera back. Uses 40 Series roll films.

November 1951-1958

**Type 1001 Land film.** For radiography. Orthochromatic.<sup>2</sup> Produces 10 x 12 in. positive prints. Picture area 9 3/8 x 10 1/2 in. 60-second development time. 100 speed.<sup>3</sup> Single exposure packets made by Polaroid and marketed through Picker X-ray Corporation for use with Picker Polaroid X-ray Cassette and Processor.

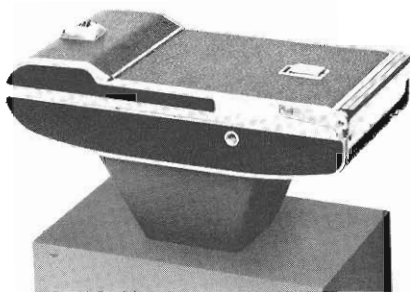

Land camera roll film back

1957

February 1957-1965

**Copymaker #208.** Standard Polaroid roll film camera is mounted on stand for making slides or paper prints from any text material, existing photographs, charts, graphs, titles, and small objects. Slides can be made in 2 1/4 x 2 1/4 in. size with Type 46 roll film for Polaroid Projector, or in 3 1/4 x 4 in. size with Type 46-L film for standard lantern slide projector.

February 1957-1964

**Model 610 projector** for 2 1/4 x 2 1/4 in. Polaroid black and white transparencies.

February 1957-1964

**Type 46 Land film.** Projection film to make finished black and white 2 1/4 x 2 1/4 in. transparencies ready for projection in two minutes. 800 speed.<sup>3</sup> Snap-together plastic mounts provided.

February 1957-to date

**Type 46-L Land film.** Same as Type 46 except for size: 3 1/4 x 4 in. for standard lantern slide projectors.

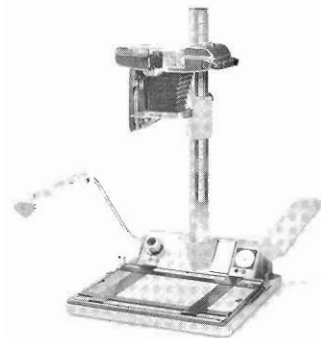

Copymaker # 208

1958

1958-to date

**Type 1001 Land film.** Improved and made panchromatic.<sup>2</sup> Speed increased to 200.<sup>3</sup>

October 1958-1968

**4 x 5 Land Film Holder #500.** Fits on back of 4 x 5 press and view cameras and uses Polaroid Series 50 4 x 5 individual film packets.

October 1958-to date

**Series 50 Land films** in 4 x 5 format. Supplied in individual light-proof "packets." Can be used only in 4 x 5 Land Film Holders. Panchromatic.<sup>2</sup>

October 1958-to date

**Type 52 Land film.** 4 x 5, paper-base negative. 60-second development time. 200 speed when introduced.<sup>3</sup> Panchromatic.<sup>2</sup>

October 1958-1961

**Type 53 Land film.** 4 x 5, acetate-base negative; produced print of outstanding quality. Negative not normally usable for making additional prints. 60-second development time. 200 speed.<sup>3</sup> Panchromatic.<sup>2</sup>

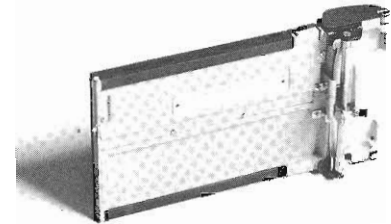

4 x 5 Land Film Holder # 500



Type 146-L Land film, Type 46-L Land film



Series 50 4 x 5 Land film packets

1961

January 1961–to date

**Type 57 Land film.** 4 x 5, paper-base negative. 10-second development time when introduced; later increased to 15 seconds. 3000 speed.<sup>3</sup> Panchromatic.<sup>2</sup>

January 1961–to date

**Type 52 Land film** converted first to 10-second development time, later to 15-second. Speed increased to 400.<sup>3</sup>

April 1961–to date

**Type 146-L Land film.** PolaLine projection film produces high contrast black and white transparency for use with standard 3¼ x 4 in. lantern slide projector. 30-second development time. 125 speed.<sup>3</sup>

February 1961–to date

**Type 3000X Land film.** Panchromatic<sup>2</sup> radiographic film produces positive 10 x 12 in. X-ray picture in 10 seconds. 3000 speed.<sup>3</sup>

September 1961–to date

**Type 55 P/N Land film.** Positive/negative 4 x 5 film. Produces fully developed negative and positive print outside darkroom. Negative made usable after treatment. 20-second development time. 50 speed.<sup>3</sup>

September 1961–to date

**Type 410 Land film.** PolaScope roll film for high speed recording. Panchromatic.<sup>2</sup> 8 exposures, 3¼ x 4¼ in. prints. 10-second development time. 10,000 speed.<sup>3</sup>

1962

January 1962–1973

**MP-3 Land camera.** Polaroid Multi-Purpose Industrial View Land camera. Versatile copy camera, valuable for macrophotography, photomicrography, copying, etc. Interchangeable lens and shutter combinations. Interchangeable film backs. Can be tilted 90 degrees for maps, wall charts, etc. Uses all 40 Series roll films, 80, 100 and 600 Series pack films, 50 Series 4 x 5 films, as well as wet process 4 x 5, roll, and 35mm films.

August 1963–1978

**CB-100 Land camera back.** Adapts various industrial and scientific instruments to use Polaroid Type 107 and 108 film packs.

December 1963–1976

**Type 58 Land film.** 4 x 5 color film. 60-second development time. 75 speed.<sup>3</sup>

1964

May 1964–1967

**Type 510 Land film.** Ultra high contrast 4 x 5 material for reproducing black and white line copy where intermediate gray tones are eliminated. 20-second development time. 10,000 speed.<sup>3</sup>

September 1964–1969

**Type 413 Land film.** Infrared film in 40 Series format. 8-exposure rolls. 3¼ x 4¼ in. prints. Depending on filtration, speed varied from 200 to 800<sup>3</sup>

November 1964–to date

**CU-5 Land camera.** Polaroid Close-up Land camera. Fixed-focus with simple exposure control. Built-in electronic flash for close-ups of small objects or areas. Easy interchange of lenses and other components for photos from ¼ life-size to 2x lifesize. Varied applications, including medical, dental, library, CRT, and other industrial uses.

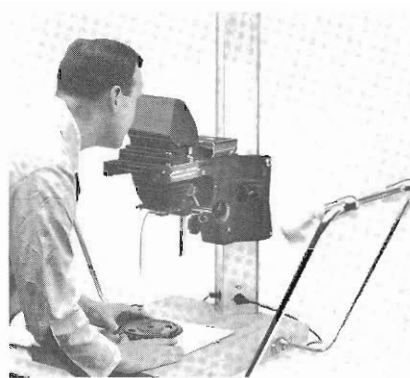

MP-3 Land camera

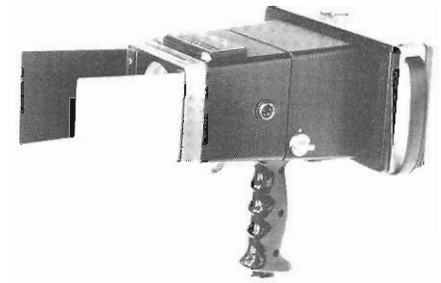

CU-5 Land camera



CB-100 Land camera back



## 1965

January 1965–1968

**Instant Portrait Land camera.** Has 6 separate lenses and shutters and produces 6 different portraits of subject on single sheet of Polaroid 4 x 5 Land film. Back of camera is removable Polaroid Land Film Holder. (Some cameras were sold in international markets in 1964.)

August 1965–to date

**XR-7 Land Diffraction Cassette.** Similar in many ways to # 500 film holder. Used with X-ray equipment for recording patterns in crystallography. Uses Type 57 film

57-1 XR-7 Land Diffraction Cassette for Laue recording.

57-2 XR-7 Land Diffraction Cassette for precession recording.

57-5 XR-7 Land Diffraction Cassette for use with Charles Supper equipment.

## 1966

April 1966–1973

**ID-2 Land Identification system** consisting of special camera and other units that produce finished color identification cards in two minutes. Two photos of subject and data information card included on one piece of film, which is first laminated under plastic, then die cut, individual photo is then sealed in plastic pouch. (Sold in GSA catalog until 1976.)

September 1966–to date

**TLX Land film.** Orthochromatic<sup>2</sup> radiographic film. 10 x 12 in. translucent prints can be viewed on illuminator or by reflected light. 45-second development time. 3000 speed.<sup>3</sup>

April 1966–to date

**CU-5 Framing Kits** for close-up photography. New industrial accessories increase possible number of field sizes and allow reproduction ratios from ¼:1 to 3:1.

## 1967

May 1967

**Type 146-L Land film.** Speed increased:<sup>2</sup> 320 under daylight/electronic flash illumination, 125 under tungsten (3200°K).

June 1967–to date

**Type 51 Land film.** 4 x 5 black and white high contrast film specifically designed for reproduction of line art work. Used with glass screen, also produces instant halftones. 15-25 second development time. Film speed:<sup>3</sup> 320 under daylight/electronic flash illumination; 125 under tungsten (3200°K).

October 1967–to date

**Instant Halftone system.** Designed to make screened halftone prints in MP-3 camera, using Type 51 High Contrast film. Consists of four glass screens (65 lines/inch to 120 lines/inch), Halftone Screen Holder and Variable Lens Aperture Attachment. Finished screened print is treated as line copy.

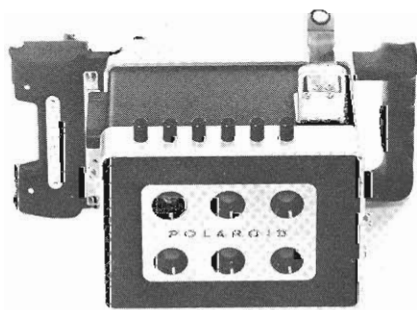

Instant Portrait Land camera



ID-2 Land Identification system

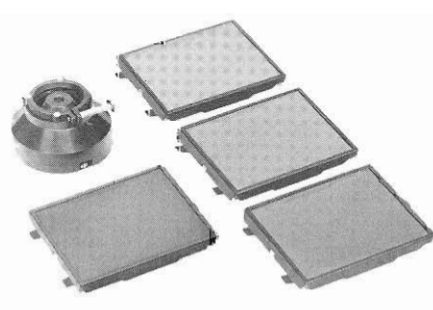

Instant Halftone system

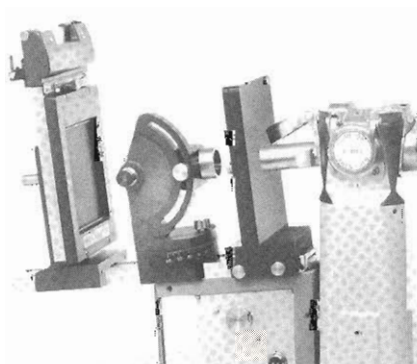

XR-7 Land Diffraction Cassette

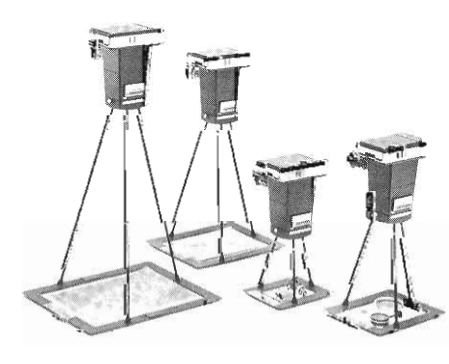

CU-5 Framing Kits

1968

March 1968–1970

**M-10 Land camera.** For low level aerial reconnaissance pictures. Combines some features of CU-5 camera with automatic shutter and exposure control of Model 250 camera. 3-element lens, front element focusing. 148mm focal length, f/11 and f/42.7. Open frame folding viewfinder.

June 1968–1975

**Special Events Land camera #228.** Complete cabinet-housed system for producing Santa and other special events pictures on continuous, high-volume basis using Type 108 Polacolor film. Consists of several components, including camera head and development timer similar to those on ID-2, two electronic flash units, each utilizing CU-5 power pack.

September 1968–to date

**4 x 5 Land Film Holder #545.**

Improved version of # 500 Film Holder.

1969

September 1969–1976

**ED-10 Land instrument camera.** With special adapter, it fits over eyepiece of microscope to provide simple method of making photomicrographs. Uses standard Type 107 black and white or Type 108 color pack films. Camera has no lens; it utilizes optical system of microscope. Subject matter is first brought into sharp focus by means of focusing tube that fits over microscope eyepiece. Then, tube is removed and camera is slipped over eyepiece for exposure.

1970

May 1970–1971

**CU-4 Land camera.** Similar to CU-5 but without Xenon electronic ring-light flash around lens. For cathode-ray tube recording; sold to manufacturers for inclusion with their systems.



M-10 Land camera



4 x 5 Land Film Holder # 545

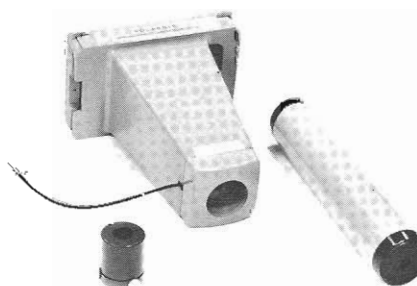

ED-10 Land instrument camera

## 1971

February 1971–1974

**Miniportrait Land cameras.** Manufactured by Cambo for international markets. Produce multiple black and white or color identification pictures in two sizes; with either Type 55P/N or Type 105P/N film, provide high quality negatives for enlargement to portrait size prints. All models have matched lenses of 125mm focal length with apertures from f/8 to f/32; shutter speeds are 1/50, 1/100 second and "B". Shutters can be set to give simultaneous or sequential exposures, and have "X" synchronization for electronic flash.

**Model 40.** Four fixed-focus lenses; subject distance 48 inches, image size 36 x 46mm on Series 100 films.<sup>4</sup>

**Model 20.** Two fixed-focus lenses; subject distance 48 inches, image size 46 x 72mm on Series 100 films.<sup>4</sup>

**Model 45.** Four variable focus lenses. Front of camera moves on track; camera can be focused either with ground glass back or superimposed rangefinder mounted on side. Image size is 44 x 56mm on either 50 Series films in # 545 Film Holder or wet process 4 x 5 films.

**Model 41.** Front end similar to Model 40; back of camera takes Series 40 roll films.<sup>4</sup> Very few were made.

February 1971–to date

**ID-3 Land Identification System.** Suitcase size carrying case contains all components needed to make and issue instant ID cards. Subject and data photographed simultaneously on one piece of film by means of two separate exposure systems. Finished print is die cut and laminated to produce highly tamper resistant card. Various types of lamination are offered; different systems use different laminators and die cutters. All systems include ID-3 camera and electronic flash and carrying case with built-in development timers and system's power components.

**Model 701.** Camera and case plus security laminator, die cutter, PolaPouch sealer.

**Model 703.** Camera and case plus Pola-Seal laminator and die cutter.

**Model 704.** Camera and case plus security laminator.

**Model 706.** Camera and case plus Dual-Bond laminator and die cutter.

**Model 707.** Camera and case plus Pola-Seal laminator and single-punch manual die cutter. (Introduced November 1973.)

For international markets, **Models 771, 773, 774 and 776** are comparable to Models 701, 703, 704 and 706, respectively, except for electrical voltage.

March 1971–to date

**CB 80 Land camera back.** Similar to CB 100 camera back except is smaller in size for use with 80 Series pack films.

July 1971–to date

**CU-5 Land camera body 88-2.** Similar to CU-5 except camera body is designed to take 4 x 5 Land Film Holder # 545.

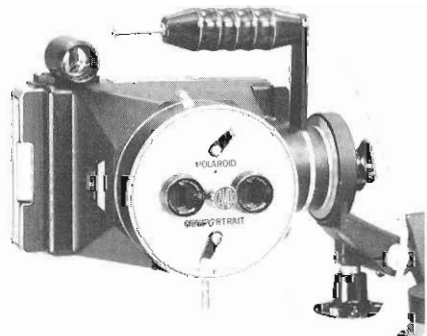

Miniportrait Land camera

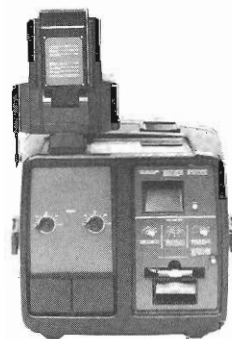

ID-3 Land Identification system (Model 703)



1972

August 1972—to date  
**CR-9 Land Oscilloscope camera.** Manufactured in United Kingdom for Polaroid. For handheld recording of cathode-ray tube tracings. Lightweight plastic body is similar to that of Model 3000 and takes Type 107 film. Fitted with fixed-focus 70mm oscilloscope recording lens, f/5.6–f/45, in Prontor self-cocking shutter. Speeds are 1/30, 1/60, 1/125 second plus "B" with "X" triggering synchronization. Interchangeable hoods fit over or into oscilloscope bezels to provide accurate focus and framing.

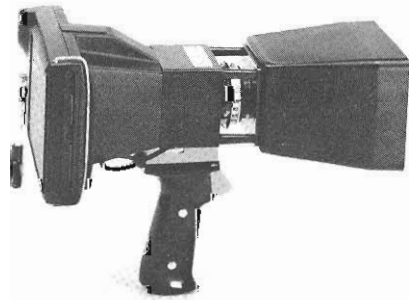

CR-9 Land Oscilloscope camera

1973

February 1973—to date  
**MP-4 Land camera.** Extremely versatile technical camera for copying, photomacrography, photomicrography, etc. Differs from MP-3 mainly by providing most features as optional additions instead of built-in components. Features include: sideways sliding camera head or fixed camera head; reflex viewer and hood; six types of glass viewing screens (2 standard, 2 aerial focusing, 2 calibrated); 360 degree tilt for camera head; adjustable light arms; condenser enlarger head. Accepts Polaroid Series 40, 50, and 100 films and some wet process films. Lenses of several focal lengths available; also various accessories such as halftone kit, microscope tube, macro extensions, etc.

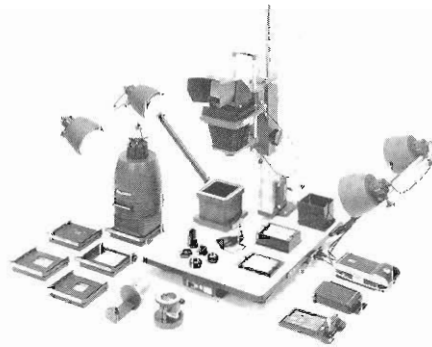

MP-4 Land camera

1974

March 1974–1977  
**Type 105 P/N Land film.** Eight-exposure film pack produces high quality black and white prints and negatives suitable for enlarging, without need of darkroom. Negative made usable after brief treatment with sodium sulfite solution and washing. 30-second development time. 75 speed.<sup>3</sup> Not discontinued in 1977 but renamed Type 665 as part of Professional Pack film line.

March 1974—to date  
**Portable Negative Clearing Tank.** Plastic tank holds 68 oz. (2000cc) of sodium sulfite solution for clearing Type 105 or Type 55 film negatives. Carrier accepts 8 negatives. Tank may be used in darkroom or on location. Negatives are placed in solution immediately after development and may be stored there for up to 72 hours, if necessary.

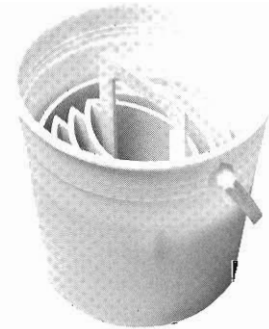

Portable Negative Clearing Tank

April 1974—to date  
**Land Pack Film Holder #405.** Lightweight plastic unit allows use of Series 100 pack films<sup>4</sup> with most 4 x 5 press or view cameras having spring backs or lock backs; also with recording and scientific instruments equipped with similar 4 x 5 backs. Holder has mini-roller spread system and flexible dark slide.

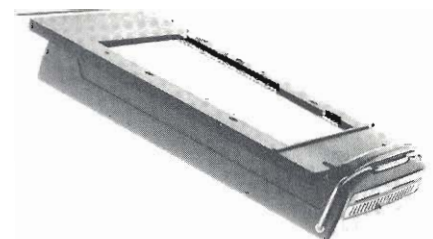

Land Pack Film Holder # 405

April 1974–to date

**CB101 Land camera back.** For use on recording instruments, etc. Similar to Pack Film Holder # 405.

April 1974–1975

**Miniportrait Land cameras.** For international markets:

**Model 401.** Similar to Model 40, except has interchangeable back utilizing version of # 405 Film Holder specially adapted to fit Miniportrait camera backs.

**Model 201.** Similar to Model 20, except has same back as Model 401.

**Model 451.** Similar to Model 45 except has improved ground glass viewing and spring back.

April 1974–to date

**Polapress Laminator and Die Cutters.** Laminator is designed to produce finished ID card to meet credit card specifications. Can produce vinyl card that contains magnetic stripe compatible with most industry and banking specifications. Laminator employs pressure and heat to emboss and bond identification card sandwich consisting of pre-cut Polaroid vinyl pouch and dry die-cut photo produced with Polaroid Land ID System.

**#S-80-70 Polapress Standard Picture Die Cutter** is designed for cutting two standard ID cards.

**#A-80-72 Polapress Stripe Picture Die Cutter** is designed for cutting two ID cards with ABA or equivalent magnetic stripe.

**#D-80-74 Polapress Double Stripe Picture Die Cutter** is designed for cutting two ID cards with Docutel or double magnetic stripe.

## 1975

March 1975–to date

**Special Events 2 Land camera.** Portable suitcase size unit contains power supply and development timers. Separate camera head has built-in electronic flash and is similar to and interchangeable with that on ID-3.

May 1975–1976

**Miniportrait cameras.** Two models were introduced in U.S.A., both manufactured by Cambo. Fixed-focus, auxiliary flash unit and auxiliary lenses.

**Model 251.** Produced two simultaneous or separate images on 4 x 5 film.

**Model 252.** Produced two simultaneous or separate images on 4 x 5 film. In addition, featured picture counter.

## 1976

January 1976–to date

**Miniportrait Land camera.** New line of Miniportrait cameras manufactured for Polaroid by Mamiya. All have these features: fixed-focus, built-in distance tape, optically matched 3-element glass lenses, bright projected image viewfinder, parallax corrected; 5 click-stop aperture settings, f/8 to f/32; 3 shutter speeds; "X" synchronization for electronic flash; interchangeable film holder; tripod socket.

**Model 253.** Introduced in U.S.A.; produces two simultaneous images on single sheet of 4 x 5 film.

**Model 452.** For international markets, produces four simultaneous images on single sheet of 4 x 5 film.

**Model 202.** For international markets, produces two simultaneous images on single sheet of pack film.

**Model 402.** For international markets, produces four simultaneous images on single sheet of pack film.

March 1976–1977

**Type 107-667 Coaterless Land film.** Similar to Type 107C, but manufactured under more stringent sensitometric specifications for medical/industrial applications.

March 1976–to date

**Type 58 Polacolor 2 Land film.** Brilliant and completely new Polacolor film made with same metallized dyes used in SX-70 film. New color negative and new positive sheet. Anti-curl photographic paper — print mounts no longer needed. Because of dye stability, pictures are extremely fade resistant.

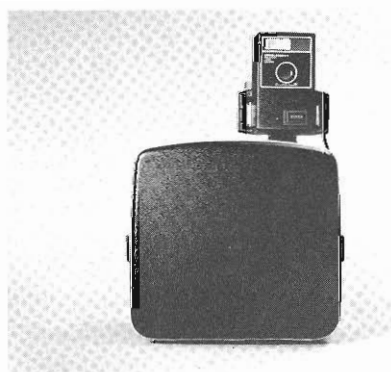

Special Events 2 Land camera system



Miniportrait Land camera Model 253

1977

March 1977–to date  
**Professional Pack Film** line introduced.

**Type 084 Black and White Land film.** Professional version of Type 107, often used for cathode-ray tube image recording. Manufactured under tightly controlled sensitometric specifications to provide adequate tonal gradation (gray scale) and sufficient exposure latitude, contrast and resolution to meet requirements of most CRT displays. 15-second development time. 3000 speed<sup>3</sup>. (Type 084 had previously been manufactured and marketed on special order basis.)

**Type 667 Coaterless Land film.** Professional version of Type 107C (previously designated Type 107-667). Coaterless version of Type 084. Development time, 30 seconds. 3000 speed<sup>3</sup>.

**Type 665 Positive/Negative Black and White Land film.** Formerly designated Type 105 P/N.

**Type 668 Polacolor 2 Land film.** Professional version of Type 108 Polacolor 2. Color balance selected especially for high speed electronic flash; emulsion bonds faster and more securely to Polaroid's ID laminating plastics; manufactured under tightly controlled sensitometric specifications to meet professional/industrial requirements.



Professional Pack Land films

September 1977–to date  
**8 x 10 Land photographic system.** Revolutionary new system which provides professional quality, full color 8 x 10 prints in instant-picture format. This system extends concept of instant photography to field of 8 x 10 and larger photography. As result, it sparked revival of interest in 8 x 10 cameras.

**Type 808 Polacolor 2 Land film.** Balanced for use in daylight and with electronic flash. Also gives excellent color rendition with tungsten illumination. Print size 8½ x 10¾ in. (22 x 27 cm). Image area 7½ x 9½ in. (19 x 23 cm). 60-second development time at 75°F. 80 speed<sup>3</sup>.

**Film Holder Model 81-05.** Fits most 8 x 10 cameras; adapts easily for use with vertical copy cameras.

**Automatic Processor Model 81-02/81-01.** Lightweight motorized film processor. Provides consistent automatic processing and timing of 8 x 10 print development. Stainless steel processing rollers, heavy-duty motor. Built-in development timer, variable from 15–90 seconds; beeper signals end of processing cycle. Size: 6 x 16 x 12½ in. (15 x 41 x 32 cm). Weight: 20 lbs.

May 1977–to date  
**Face Place Automatic Portrait Studio.** Self-contained, self-portrait vending booth. Accommodates one or two adults or up to three children. When user inserts money, countdown sequence lights up. At end of sequence flash goes off, picture is taken and customer is handed developing SX-70 picture. Uses Polaroid Type 708 SX-70 film.

**Type 708 SX-70 Land film.** Similar to SX-70 Land film except there is no battery. For use in Face Place Automatic Portrait Studio.

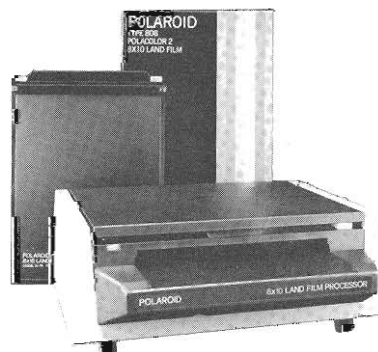

Instant 8 x 10 Photographic system

1978

January 1978–to date  
**Minipportrait Land cameras** given wider distribution. Models 452 and 202 sold within U.S.A. Model 253 sold in Canada and Japan.

March 1978–to date  
**Recording ID-3 camera.** Similar to ID-3 camera with added Super 8 movie camera to provide file copies of all ID pictures produced.

**Recording ID Copier.** Accessory which copies Super 8 film onto 4 x 5 film for additional records.

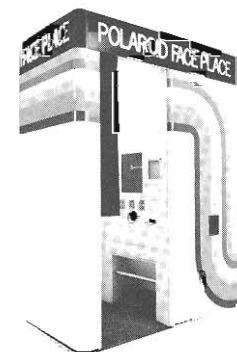

Face Place Automatic Portrait Studio



**Suggested list prices of some major  
Polaroid products at time of  
introduction\***

**Amateur Products**

Model 95 Land camera	\$89.75
Type 40 Land film	\$1.75
Model 110 Land camera	\$249.50
Model 95A Land camera	\$89.75
Model 80 Land camera	\$69.95
Type 42 Land film* (1956)	\$1.98
Type 32 Land film* (1956)	\$1.53
Model 700 Land camera	\$125.00
Model 95B Land camera	\$94.50
Model 80A Land camera	\$72.75
Model 150 Land camera	\$109.95
Model 800 Land camera	\$126.00
Model 110A Land camera	\$169.50
Print Copier	\$29.95
Type 47 Land film	\$2.29
Model 250 Wink-Light	\$17.95
Model 440 Photoelectric shutter	\$39.95
Model 80B Land camera	\$72.75
Type 37 Land film	\$1.79
Model 110B Land camera	\$172.50
Model 900 Land camera	\$159.95
Model 850 Land camera	\$139.95
Model J66 Land camera	\$89.50
Model J33 Land camera	\$74.95
Type 48 Land film	\$3.55
Type 38 Land film	\$2.65
Type 107 Land film	\$1.92
Type 108 Land film	\$4.38
Model 100 Land camera	\$164.95
Model 101 Land camera	\$134.95
Model 103 Land camera	\$89.95
Model 104 Land camera	\$59.95
Model 20 (Swinger) Land camera	\$19.95
Type 20 Land film	\$1.99
Model 180 Land camera	\$189.95
Model 250 Land camera	\$159.95
Model 240 Land camera	\$129.95
Model 230 Land camera	\$99.95
Model 220 Land camera	\$74.95
Model 210 Land camera	\$49.95
Model 3000 Land camera	\$24.95
Model 360 Land camera	\$199.95
Model 350 Land camera	\$149.95
Model 340 Land camera	\$99.95
Model 330 Land camera	\$79.95
Model 320 Land camera	\$59.95
Colorpack II Land camera	\$29.95
Colorpack III Land camera	\$39.95
Model 450 Land camera	\$164.95
Model 440 Land camera	\$99.95
Model 430 Land camera	\$79.95
Model 420 Land camera	\$59.95
Big Shot Land camera	\$19.95
Type 88 Land film* (1972)	\$3.99
Type 87 Land film* (1974)	\$3.10
Super Colorpack Land camera	\$44.95
Square Shooter Land camera	\$34.95
Square Shooter II Land camera	\$24.95
SX-70 Land film	\$6.90
SX-70 Land camera (deluxe)	\$180.00

The Colorpack Land camera	\$39.95
Model 195 Land camera	\$199.95
Zip Land camera	\$13.95
SX-70 Model 2 Land camera	\$149.95
Super Shooter Land camera	\$25.00
SX-70 Model 3 Land camera	\$99.95
Electric Zip Land camera	\$21.95
Pronto! Land camera	\$66.00
SX-70 Alpha 1 Land camera	\$233.00
SX-70 Alpha Model 2 Land camera	\$180.00
Pronto! B Land camera	\$59.00
Pronto! RF Land camera	\$88.00
Minute Maker Land camera	\$24.95
The Reporter Land camera	\$57.00
OneStep Land camera	\$39.95
Polavision Land camera	\$210.00
Polavision Land player	\$465.00
Polavision Phototape cassette	\$9.95
SX-70 Sonar OneStep Land camera	\$249.95
Pronto! Sonar OneStep Land camera	\$99.95
Model 600 SE Land camera	\$525.00

**Industrial Products**

Copymaker # 208	\$99.75
Model 610 projector	\$109.75
Series 50 Land films* (1971)	
Type 51 20 packets	\$14.50
Type 52 20 packets	\$13.50
Type 55 20 packets	\$15.50
Type 57 20 packets	\$13.50
Type 58 10 packets	\$13.50
4 x 5 Land Film Holder # 500	\$41.00
MP-3 Land camera	
38 in. column without lens, shutter or camera back	\$423.00
CB-100 Land camera back	\$67.00
CU-5 Land camera	
camera body and grip	\$75.00
ID-2 Land Identification camera	\$1700.00
XR-7 Land Diffraction cassette	\$325.00
4 x 5 Land Film Holder # 545	\$72.00
ED-10 Land camera	\$69.95
ID-3 Land Identification	
system — camera, laminator, die cutter and sealer	\$1800.00
CR-9 Land Oscilloscope camera	\$160.00
MP-4 Land camera	
camera body with 35 in. fixed column only	\$310.00
Special Events 2 Land camera	\$990.00
Miniportrait Land camera	
Model 253	\$475.00
Model 452	\$545.00
Model 202	\$495.00
Type 808 Land film	
10 packets	\$56.00
Land Film Holder Model 81-05	\$49.50
Land Film Processor	
Model 81-02/81-01	\$495.00
Face Place Portrait Studio	\$7890.00

\* unless otherwise noted

---

## INDEX

### Amateur Products

	Page		
Big Shot Portrait Land camera	12	Model 95 Land camera	4
Clincher Land camera, The	14	Model 95A Land camera	5
Clincher 2 Land camera	16	Model 95B Land camera	6
Colorpack Land camera, The	13	Model 100 Land camera (roll film)	5
Colorpack II Land camera	11	Model 100 Land camera (pack film)	8
Colorpack III Land camera	11	Model 101 Land camera	9
Colorpack IV Land camera	11	Model 102 Land camera	9
Colorpack 5 Land camera	13	Model 103 Land camera	9
Colorpack 80 Land camera	12	Model 104 Land camera	9
Colorpack 82 Land camera	12	Model 110 Land camera	4
Colorpack 85 Land camera	12	Model 110A Land camera	6
Colorpack 88 Land camera	12	Model 110B Land camera	7
Colorpack 100 Land camera	14	Model 120 Land camera	7
Colorpack 200 Land camera	17	Model 125 Land camera	9
Colorpack M6 Land camera	11	Model 135 Land camera	9
Colour Swinger Land camera	14	Model 150 Land camera	6
Colour Swinger II Land camera	14	Model 160 Land camera	8
Countdown 70 Land camera	11	Model 180 Land camera	9
Countdown 90 Land camera	11	Model 190 Land camera	14
Countdown M60 Land camera	11	Model 195 Land camera	14
Countdown M80 Land camera	11	Model 195 SE Land camera	14
EE 22 Land camera	15	Model 210 Land camera	10
EE 33 Land camera	15	Model 215 Land camera	10
EE 38 Land camera	16	Model 220 Land camera	10
EE 44 Land camera	15	Model 225 Land camera	10
EE 55 Land camera	15	Model 230 Land camera	10
EE 58 Land camera	16	Model 240 Land camera	10
EE 60 Land camera	15	Model 250 Land camera	10
EE 66 Land camera	15	Model 315 Land camera	11
EE 66 Land camera	15	Model 320 Land camera	10
EE 88 Land camera	16	Model 325 Land camera	11
EE 100 Land camera	16	Model 330 Land camera	10
Electric Zip Land camera	15	Model 335 Land camera	11
Encore! Land camera	17	Model 340 Land camera	10
Instant 10 Land camera	17	Model 350 Land camera	10
Instant 20 Land camera	17	Model 355 Land camera	14
Instant 30 Land camera	17	Model 360 Land camera	10
M15 Swinger Sentinel	9	Model 415 Land camera	9
MemoryMaker Land camera	17	Model 420 Land camera	11
Mini-roller developer spread system	12	Model 430 Land camera	11
MinuteMaker Land camera	17	Model 440 Land camera	11
MinuteMaker BC Land camera	17	Model 450 Land camera	11
MinuteMaker Plus Land camera	17	Model 455 Land camera	14
MinuteMaker Plus SE Land camera	17	Model 600 Land camera	18
Model 20 Land camera (The Swinger)	9	Model 600 SE Land camera	18
Model 80 Land camera	5	Model 700 Land camera	5
Model 80A Land camera	6	Model 800 Land camera	6
Model 80B Land camera	7	Model 850 Land camera	7

Model 900 Land camera	7	Super Colorpack Land camera	12
Model 1000 Land camera	17	Super Colorpack IV Land camera	12
Model 1500 Land camera	16	Super Shooter Land camera	14
Model 2000 Land camera	16	Super Shooter Plus Land camera	14
Model 3000 Land camera (Big Swinger)	10	Super Shooter SE Land camera	14
Model 3000 Land camera (Pronto! type; international)	16	Super Swinger Land camera	14
Model J33 Land camera	7	SX-70 Alpha 1 Land camera	16
Model J66 Land camera	7	SX-70 Alpha Land camera, Sears Special	16
OneStep Land camera	17	SX-70 Alpha Executive Land camera	16
OneStep Land camera, Sears Special	17	SX-70 Alpha Model 2 Land camera	16
OneStep BC Land camera	17	SX-70 Alpha SE Land camera	16
OneStep SE Land camera	17	SX-70 Executive Land camera	14
Photoelectric shutter # 440	7	SX-70 Land camera (Deluxe)	13, 14, 16
Photoelectric shutter = 440A	7	SX-70 Land camera BC	14
Polatronic Flash	16	SX-70 Land film	13, 16, 18
Polavision Instant Replay Control	18	SX-70 Model 2 Land camera	14
Polavision Land camera	17	SX-70 Model 2 Executive Land camera	14
Polavision Land Player	18	SX-70 Model 3 Land camera	15
Polavision Phototape Cassette	18	SX-70 SE Land camera	15
Polavision TwiLight	18	SX-70 Sonar OneStep Land camera	18
Presto! Land camera	17	Swinger, The (Model 20)	9
Print Copier Model 230	6	Swinger EE Land camera	15
Print Copier Model 240	6	Tele 1.5 Lens # 119	18
Print Copier Model 2401	6	Tele 1.5 Lens # 124	18
Pronto! Land camera	15	Type 20 Land film	9
Pronto! Land camera, Sears Special	16	Type 20C Land film	11
Pronto! B Land camera	16	Type 31 Land film	5
Pronto! BC Land camera	17	Type 32 Land film	5, 7
Pronto! BC Rangefinder Land camera	16	Type 37 Land film	7
Pronto! Extra Land camera	17	Type 38 Land film	8
Pronto! Plus Land camera	15	Type 40 Land film	4
Pronto! RF Land camera	16	Type 41 Land film	4
Pronto! RF Land camera, Sears Special	16	Type 42 Land film	5
Pronto! RF SE Land camera	16	Type 43 Land film	5
Pronto! S Land camera	15	Type 44 Land film	5
Pronto! SE Land camera	15	Type 47 Land film	7
Pronto! SM Land camera	15	Type 48 Land film	8
Pronto! Sonar OneStep Land camera	18	Type 87 Land film	12, 14
Reporter Land camera, The	17	Type 88 Land film	12
Reporter SE Land camera, The	17	Type 88 Polacolor 2 Land film	16
Square Shooter Land camera	12	Type 107 Land film	8
Square Shooter 2 Land camera	13	Type 107C Land film	18
Square Shooter 4 Land camera	13	Type 108 Land film	8
Super Clincher Land camera	16	Type 108 Polacolor 2 Land film	14
Super Colour Swinger Land camera	15	Wink-Light # 250	7
Super Colour Swinger II Land camera	15	Wink-Light = 252	7
Super Colour Swinger III Land camera	15	Zip Land camera	12, 14



---

## INDEX

<b>Professional/Industrial Products</b>	<b>Page</b>
Automatic Processor Model 81-02/81-01	26
CB 40 Land camera back	
(see Land camera roll film back)	19
CB 80 Land camera back	23
CB 100 Land camera back	20
CB 101 Land camera back	25
Copymaker # 208	19
CR 9 Land Oscilloscope camera	24
CU-4 Land camera	22
CU-5 Framing Kits	21
CU-5 Land camera	20
CU-5 Land camera body 88-2	23
ED-10 Land Instrument camera	22
FacePlace Automatic Portrait Studio	26
Film Holder Model 81-05	26
ID-2 Land Identification system	21
ID-3 Land Identification system	23
Instant Halftone System	21
Instant Portrait Land camera	21
Land camera roll film back	19
Land 4 x 5 Film Holder # 500	19
Land 4 x 5 Film Holder # 545	22
Land Pack Film Holder # 405	24
M-10 Land camera	22
MP-3 Land camera	20
Miniportrait Land camera	23, 25, 26
Model 600 Land camera	18
Model 600 SE Land camera	18
Model 610 Projector	19
MP-4 Land camera	24
PolaPress Laminator and Die Cutters	25
Portable Negative Clearing Tank	24
Recording ID-3 camera	26
Recording ID-3 copier	26
Special Events Land camera # 228	22
Special Events 2 Land camera	25
TLX Land film	21
Type 46 Land film	19
Type 46-L Land film	19
Type 51 Land film	21
Type 52 Land film	19, 20
Type 53 Land film	19
Type 55 P/N Land film	20
Type 57 Land film	20
Type 58 Land film	20, 25
Type 084 Black and White Land film	26
Type 105 P/N Land film	24
Type 107-667 Land film	25
Type 146-L Land film	20, 21
Type 410 Land film	20
Type 413 Land film	20
Type 510 Land film	20
Type 665 Positive/Negative Black and White Land film	26
Type 667 Coaterless Land film	26
Type 668 Polacolor 2 Land film	26
Type 708 SX-70 Land film	26
Type 808 Polacolor 2 Land film	26
Type 1001 Land film	19
Type 3000X Land film	20
XR-7 Land Diffraction Cassettes	21



